

February

1941

Radio

SERVICE DEALER

This Month

REALLOCATION DATA

L-P PHONO PICKUPS

SET RECONDITIONING

RSD STORE PLACARDS

HIGH-FIDELITY SETS

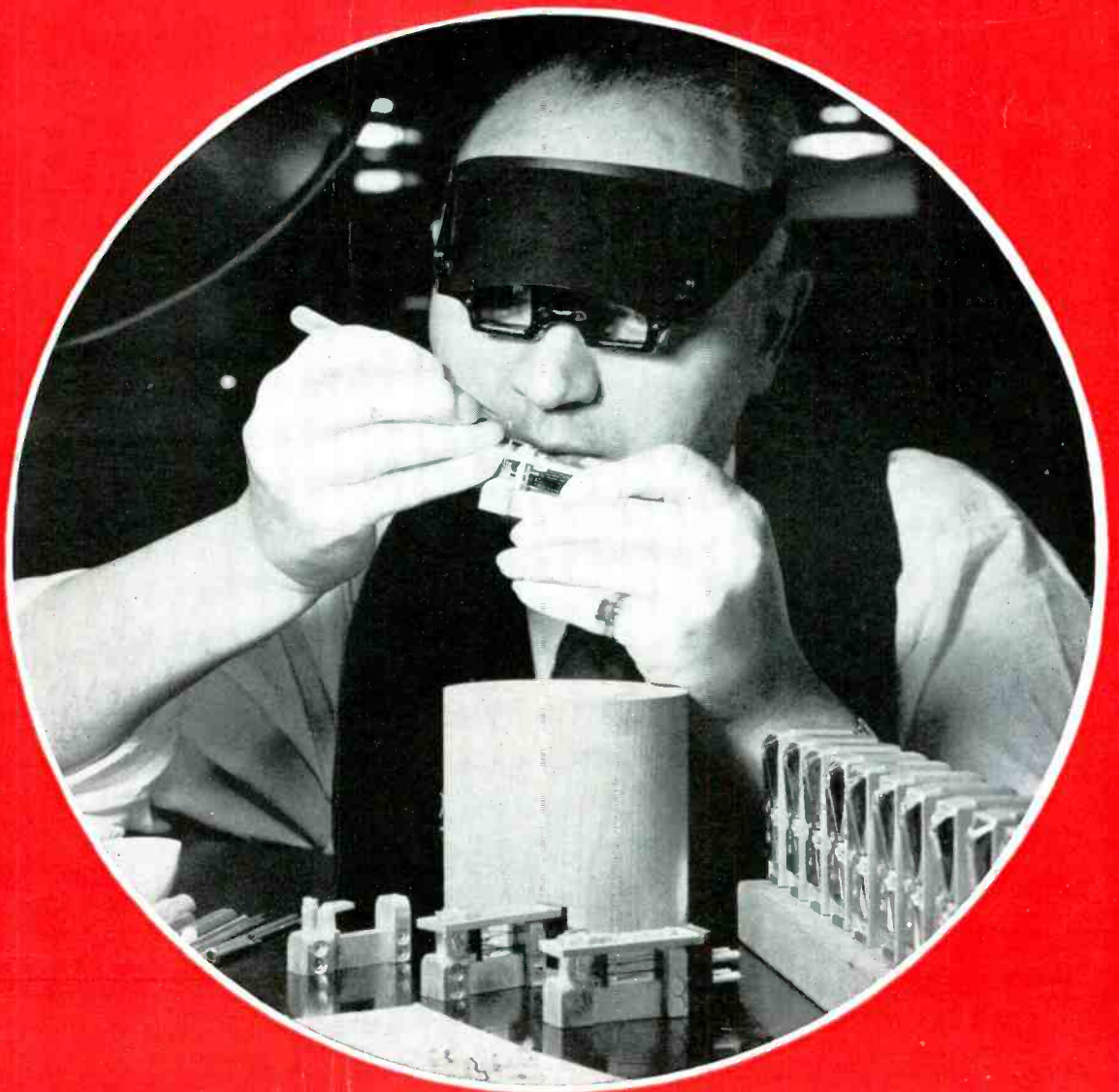

Price

25¢

Clear the Track
for a NEW RADIOLA



..here comes the

515!



**2-BAND AMERICAN
AND FOREIGN RECEPTION**
plus all these features

\$24⁹⁵ EASTERN LIST PRICE

Wrap-Around Cabinet of Costly Woods
2 Built-in Loops: Long Waves and Short
Big, Modern, Easy-Reading Horizontal
Dial
R-F Stage—Phenograph Jack & Switch
Positive A.V.C. Action—Tone Control

Equipped Exclusively with RCA Preferred Type Tubes

For Speedy Sales by SERVICEMEN

- 6 TUBES WITH R-F STAGE

It's a fast-moving, super-powered express to profits unlimited, this new Radiola 515! Sales-slanted . . . feature-filled . . . designed and manufactured for *servicemen* to sell!

It's the latest addition to the great new line that's backed by a grand old name . . . RADIOLA—the line that has already put thousands of dollars in servicemen's pockets all over the country. The new 515 has all the money-making

features of the other Radiolas—and *more*. Foreign reception. *Two* built-in Antennas. 6 RCA Preferred Type Tubes. A stage of R-F amplification ahead of the sensitive superheterodyne circuit for extra sensitivity and higher signal-to-noise ratio.

Designed to sell on performance, it's *built* to perform . . . and how! See it—hear it—at your Radiola Distributor's, and you'll agree: "For *profits*, ride the 515 to town!"



Radiola Preferred Type Radios

Made by RCA Manufacturing Company, Inc., Camden, N. J., U. S. A.
A Service of the Radio Corporation of America

Radio SERVICE-DEALER

SOUNDMAN AND JOBBER

Reg. U. S. Pat. Off.

Ad Index

Aerovox Corporation	33
L-C Checker	
Astatic Microphone Labs., Inc.	25
Low-Pressure Crystal Pickups	
Brach Mfg. Corp., L. S.	35
Auto & Home Antennae	
Burgess Battery Co.	35
"A" & "B" Batteries	
Centralab	3rd Cover
Portable Adashaft Kit	
Cinaudagraph Speakers, Inc.	34
Loudspeakers	
Electrovox Company	34
Walco Sapphire Needles	
General Industries Co., The	26
R-70 Home Recording Unit	
Guardian Electric Co.	31
A-100 Change-over Relay	
Hygrade Sylvania Corp.	32
Radio Chassis Chart	
International Resistance Co.	29
Adjustable 10-Watt Resistors	
Jackson Elec. Inst. Co., The	35
Model 636 Dynamic Tube Tester	
Meissner Mfg. Co.	30
F-M Receptor	
Mueller Electric Co.	35
Battery & Connector Clips	
National Union Radio Corp.	4th Cover
Service-Dealer Honor Roll	
Ohmite Manufacturing Co.	33
Calculator & Resistors	
Racon Electric Co.	2
Horn & Trumpet Speakers	
Radio Parts Mfgs.	34
National Trade Show	
Radio Servicemen of America	36
Membership	
Raytheon Production Corp.	9
Tubes for Welding Control	
RCA Mfg. Co., Inc.	2nd Cover
Radiola 515	
Simpson Electric Co.	4
Model 450 "Test Master"	
Sprague Products Co.	31
Condensers	
Sundt Engineering Co.	34
Carillons	
Supreme Instruments Corp.	26
Model 504-A Tube & Set Tester	
Triplet Elec. Inst. Co.	30
Model 1183 Combination Tester	
Utah Radio Products Co.	28
Bi-Directional Speakers	
Webber Co., Earl	32
Model 230 Signal Tracer	

Contents

Transients (Editorial)	
Adapting F.M.	3
Remote Control	3
Reconditioning	3
Low-Pressure Phono Pickups	5
By G. S. Granger	
Radio's Moving Day	8
Consumers' Placard	10
Conditioning the Consumer	11
Set of the Month—	
Motorola Model 35-F	12
Sales Hints for Servicers	14
Technical Service Portfolio:	
Section VIII—	
High-Fidelity Receivers	15
Set-Reconditioning Drive	18
Serviceman's Diary	19
By J. P. Hollister	
Circuit Court:	
I-F "Contact" Bias	20
Killed Oscillator	20
Hi-Lo AC-DC	20
Diode-Biased A.F.	20
Class B Feedback	21
Ganged Heaters	21
Silencing Bias	21
New Products	22-24
Shop Notes:	
RCA 0-2, 0-6 Motor Adjustments	23
RCA 1629 Electron-Ray Tube	23
Silvertone Model 7327 Alignment Precaution	23
Silvertone Model 7325 Band-Spread Alignment	23
Wells-Gardner 6A43-1, 6A43-3 Hum.	23
News	24
New Literature	24
F-M Station Designations	32
Radio in National Defense	34

Cover Photo

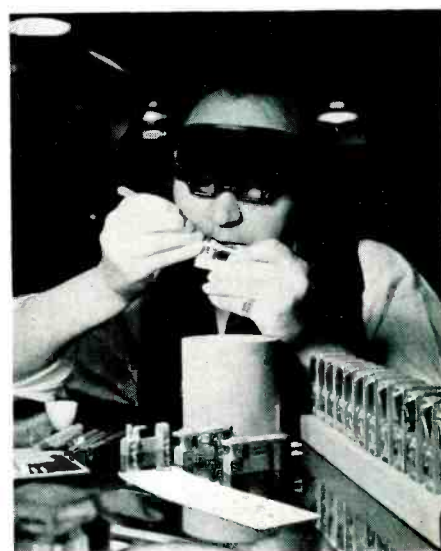

★ Skill and steady hands are essentials of the job of inserting the diamond stylus in the Western Electric 9A Reproducer. This pickup is representative of the new low-pressure designs that have been recently introduced, and which preserve the records. See article on page 5.

Published Monthly by

COWAN PUBLISHING CORP.

11 WEST 42nd ST., NEW YORK, N. Y.

Telephone: CHickering 4-3278-9

M. L. MUHLEMAN, EDITOR
S. R. COWAN, ADV. MANAGER

Subscription rate, \$2.00 a year in United States. Single copies, 25 cents. In foreign countries and Canada, \$3.00 a year. Editorial and advertising offices, 11 West 42nd St., New York, N. Y.

VOL. 2 No. 2 ★ FEBRUARY, 1941

NO SALES TO-DAY-



...but, sales ZOOM
when RACONs are used

Until recently buyers of sound equipment and p-a systems would 'go for' anything that looked impressive. That old-fashioned idea became passé as Soundmen learned that performance and dependability are the paramount issues. RACON sales have consistently forged upwards to new heights because RACON Speakers, Horns and Units not only look impressive but in operation—over a long period of time and under extremely hard usage — outperform all other makes. RACON PRODUCTS are competitively priced yet they provide a greater profit margin to the soundman, and optimum satisfaction to the buyer. When figuring on prospective sound sales and rentals specify RACONs—you won't hear "No Sales Today."

RACON—the oldest, largest and foremost manufacturer of air-column speakers in the world produces all types for every kind of sound installation. It is the only complete line made. Ask your jobber for a new catalog or write direct to the main office in New York.

MARINE HORN SPEAKERS

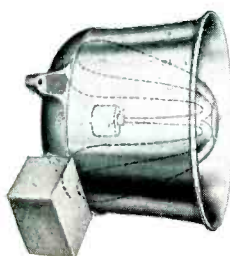

Re-entrant type speakers using horn type units for marine and general P-A applications — may be used as loud-speaker or as a microphone. Miniature and regular sizes approved by the

Bureau of Marine Inspection and Navigation, Department of Commerce, for marine work. In all sizes, miniature, midget, regular and bull, handling from 5 to 50 watts.



RACON P. M. HORN UNITS

Operating capacity 12-15 watts, peak 25 watts. Other P.M. units available from "baby unit" of 5 watts to "bull unit" with an operating capacity of 50 watts. Efficiencies of the highest order obtainable with the finest magnetic material and steel utilized.

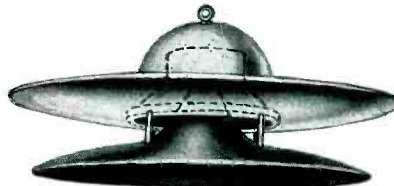

RADIAL CONE SPEAKERS

Types for high fidelity, giving even intensity sound projection over a circumference of 360° radially. Upper deflector made of heavy gauge aluminum, cone covering of steel, and lower deflector of RACON ACOUSTIC material storm-proofed for all weather conditions. Models for 5"—6"—10"—12" cone speakers.

Re-Entrant Trumpets

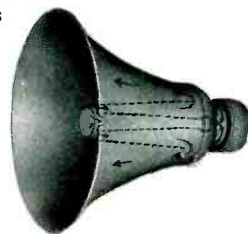

A compact trumpet of the double re-entrant type. Occupies but a small space, nevertheless has a long air column enabling it to deliver

highly concentrated sound of the greatest efficiency over long distances. Base and inside cone arm made of aluminum castings, outside bell of heavy gauge aluminum spinning, center section of RACON ACOUSTIC material to prevent resonant effects. Available in 6', 4½', 3½', and 3' air column units.

RACON ELECTRIC CO. 52 EAST 19th ST. NEW YORK, N. Y.

Transients

ADAPTING F. M. . . . In any appraisal of frequency-modulation broadcasting, there are two prime advantages to be considered. The first—that of noiseless reception—is not open to argument; it is a clear-cut advantage under all conditions and offers the listener a distinct improvement in radio reception. By virtue of its infallibility, and the relief it provides from man-made noise and summer static, it is Sales Point No. 1.

The actual value of the extended tonal and volume range of f-m broadcasting, however, is open to argument. It is all very well to talk in terms of increased dynamic range and a frequency response of the order of 30 to 15,000 cycles, but until such time as the majority of f-m programs originate in the stations' studios, or wire lines are equalized to accommodate the full range, the best of f-m receivers can offer little more, on the average, than a good high-fidelity a-m set. For that matter, the a-m receiver of good quality may have an edge on the f-m job in many cases because of the required differences in microphone technique. If the program is picked off an a-m chain, the chances are that it will sound better coming from a high-fidelity a-m set than from an f-m receiver capable of reproducing the complete tonal range.

The point involved is, that for the time being, an expensive, wide-range f-m receiver is put to somewhat of a disadvantage by the tonal quality of many of the transmitted programs. Hence—until the programs are improved—it is better to consider f-m reception as the equivalent of that obtained from a high-fidelity a-m receiver—plus the added advantage of the no-noise feature.

That's still a lot to crow about. At the same time, viewed in this less optimistic light, it removes the disadvantage originally assigned to the f-m tuner or adapter—the point of contention having been that the audio system in the average console receiver falls far short of the frequency range involved in f-m.

This, of course, is partially true, but many have overlooked the fact that such audio systems can be considerably extended in range with little difficulty and at comparatively low cost. The ampli-

fier itself can be improved by the addition of inverse feed-back, even though the transformer or transformers in the audio system are cheap affairs. The use of a higher gain tube in the first a-f stage will make up for the loss introduced by the feed-back loop. Excellent speakers with an average range of 50 to 10,000 cycles are now available at very low cost.

Any serviceman should be able to jazz up an old job at a very reasonable figure, and make a sale on an f-m tuner to boot.

A large number of inexpensive f-m tuners have been placed on the market within the past few months. They will bring the advantages of frequency modulation to the average consumer who cannot afford an expensive f-m receiver. With the assistance of a serviceman, said average consumer can enjoy moderately high-quality, noiseless radio reception at small cost. It is your chance to cash in.

★

REMOTE CONTROL . . . Aside from the fact that most of us would like to see all midget sets selling at higher prices, what is generally wrong with them? Principally the loudspeaker and the small baffle area. Otherwise, they're pretty good for local reception.

If you've never tried it, you're in for a bit of a surprise when you feed a midget into an external speaker with a diameter of 8 inches or more, mounted on a good baffle. A little 5-tube ac-dc job can work wonders under such conditions.

All of which leaves an opening for what may be called remote control. There are, as you know, loads of people who insist on getting along with a midget set, even though the tone is admittedly below par. And many other people who will cuss to high heaven rather than get up and tune out a lousy program, once they are set for the evening.

You, as a serviceman, can offer good tone and remote control to both groups. The midget can be hauled out of the bookcase (where it invariably is) and placed within reach of the armchair. A p-m speaker can take the place of the midget in the bookcase, or sold to the

customer in a bass reflex or infinite baffle cabinet.

The leads from the midget to the external speaker can be 50 feet or more in length without introducing any particular losses, providing it is a low-impedance line. This it will be if the output transformer in the midget is used, or replaced by one that will match the voice-coil impedance of the external speaker. The midget speaker can be killed, or a switch installed so that either speaker may be used.

With good p-m speakers selling at such low figures, it's foolish to overlook this sales possibility.

★

RECONDITIONING . . . There's an interesting article in this issue on how the Spokane Radio Company boosted the radio servicing business in the Northwest, in turn boosted their own business, and, far from incidentally, insured hundreds if not thousands of consumers against premature receiver breakdown. Don't fail to read it.

A reconditioning plan is something that should be promoted in every community. Far from being an objectionable practice, as some might assume it to be, it is actually a money-saver for the consumer. People are conscious of the fact that cars and vacuum cleaners, for instance, are less subject to major breakdowns if the minor faults are taken care of periodically. The reason so few consumers are conscious of this in conjunction with radio lies in their unfounded opinion that only moving parts are subject to wear.

Some servicemen may be of the opinion that it's just as well to leave the consumer uninformed, since there's more money to be made on a major breakdown. Actually, this is also a fallacy. There is a more consistent income to be had, and more good will to be spread around through a reconditioning plan carrying an equitable testing charge or flat overhaul fee that offers the consumer real insurance, than in any system based on waiting until your customers' receivers go bloop in a big way.

EDITOR



**MODEL 450
"TEST MASTER"**

Here the Model 300 is broadened to cover set testing. In addition to the tube tests of the No. 300 it has, as a set tester, 8 A.C. voltage ranges; 5 resistance ranges; 5 millamp ranges; 5 Decibel ranges. Your net price..... **\$3975**



MODEL 300 TUBE TESTER

Here is a typical Simpson value. Tests locals, single ended tubes, bantams, midgets, miniature, ballast tube, gaseous rectifiers, Christmas bulbs, etc. Filament voltage from .5 to 120 V. Has three-way switching, neon short check, "good" and "bad" scale; percentage scale; tube charts in cover. Your net price..... **\$2650**

Who builds the best testers?

AFTER all, there can only be one *best* in any field. Who makes it? Who makes the best automobile—or screwdriver—or anything you need?

People are asking that question with more intensity today than they ever asked it before . . . and they *should*. Twenty years ago, when every manufacturer worked with practically the same materials and methods that everyone else in his field used, the best thing in any field was almost necessarily the highest priced thing available. But in recent years people have had their eyes opened.

Today, materials and methods and ideas are changing so rapidly that the manufacturer who held the lead *last* year may very easily *lose* it *this* year. You have seen makes of high priced automobiles pass into oblivion, not because they were not conscientiously built but because someone saw a "smart way" to make nine hundred dollar's worth of machinery do tricks that three thousand dollar's worth had failed to accomplish!

In the light of examples like that, we invite you to ask the question, "who builds the best testers?" In

seeking the answer forget manufacturers' names entirely and weigh basic worth against basic worth—idea against idea—workmanship against workmanship—record against record—straight through the list of radio testing equipment.

In such a comparison, we feel confident that you will find in Simpson Testers another one of those examples of smarter coordination of materials, methods and ideas that is re-shaping the trend of an industry.

Why? Because we came into the field with unsurpassed experience, but with a totally *fresh* viewpoint. That combination of advantages inspired the finer Simpson basic meter with bridge-type construction and soft iron pole pieces . . . the Roto-Ranger idea . . . the three-way switching idea . . . the "replaceable unit" idea . . . the countless other ideas that jolted testing equipment out of the rut into which it had fallen.

Three examples of this—but only three of the many—are illustrated here. Consider the *extra value* that these instruments represent and you have the answer to that vital question: "Who makes the best?"

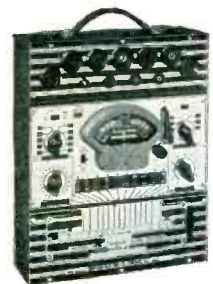

**MODEL 400
TUBE TESTER**

A useful and impressive instrument. "Unit design" guards against obsolescence. Note visual guide tied in with new, Simpson speed-roll chart. Has three-way switching. Your name engraved free on panel at net price of..... **\$3600**

SIMPSON ELECTRIC COMPANY

5216-18 Kinzie Street, Chicago, Illinois

Simpson

INSTRUMENTS THAT STAY ACCURATE

RADIO SERVICE-DEALER; FEBRUARY, 1941

LOW-PRESSURE PHONO PICKUPS

By G. S. GRANGER

SINCE the inception of the "electric phonograph," commercial records and record reproducers have seldom occupied the same rung on the ladder of progress. Either the records have fallen short of that which the reproducers were capable of delivering, or the reproducers were not up to providing the full quality caught in the recording. With the passing of time, the two have see-sawed upward, each gaining or losing the edge that has become increasingly less apparent.

THE RECORD PROBLEM

As matters stand today, the reproducer—and particularly the pickup—has the edge on the commercial record, though not for any lack of ingenuity on the part of the record makers. The situation insofar as the record is concerned is controlled by the general nature of the phonograph equipment in public use. The controlling factor has been and is record wear. So long as the majority of the equipment in use is of such a nature as to wear record surfaces, the manufacturer must necessarily incorporate a percentage of abrasive material in the rec-



The Astatic FP-18, FP-38 low-pressure crystal pickup with built-in sapphire stylus.

ord compound to give it greater resistance to wear. Coincidentally, the surface noise or hiss caused by this abrasive has been a retarding factor in increasing the frequency range recorded, as has been the range of the average phonograph in use.

Nevertheless, the introduction of the relatively light-weight crystal pickup permitted a reduction in the percentage of abrasive employed in the record pressings, and this in turn permitted the recording of a wider frequency range. Moreover, general improvements in the design of the audio amplifiers and loudspeakers employed in the more recent phono-radio combinations made an increase in both tonal and volume range of recordings a feature that could be at least partially appreciated by the public. Whereas at one time the upper recording limit was 5000 cycles or less, the newer records contain frequencies out to 7500

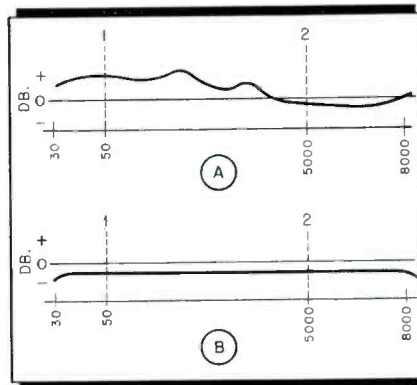

Fig. 1. The characteristics shown are purely ictional and any resemblance to actual pickup characteristics is coincidental! See text.

cycles—the equivalent of high-fidelity radio reception if the complete range is reproduced. Bass response has also been extended and is usable where compensation is employed.

THE NEW PICKUPS

Motivated possibly by the increased popularity of instantaneous recording, the pickup manufacturers have, in the meantime, drawn ahead of the record manufacturers, and brought out crystal, magnetic and dynamic pickups that far exceed the requirements of the commercial record. These new pickups answer practically all of the problems involved in the reproduction of recorded sound.

As time will prove, the most important feature of these new pickups is the practical elimination of record wear, and the advantage of this is not so much that new records will stand up for years but rather that they will not develop high scratch level and distortion during their useful period of five to ten years before they are made technically obsolete.

The feature next in importance is the practicality of employing a needle of the long-playing type as a permanent or semi-permanent installation, as the factor responsible for the reduction of record wear to a negligible point works both ways; record and needle wear is reduced proportionately.

Other advantages of these new pickups are: wider frequency range, flatter response with proper equalization, reduction if not elimination of needle chatter and pickup-arm resonances, better tracking, and—even though the full response

may be used—relatively less needle scratch.

BUSINESS POSSIBILITIES

If the obvious advantages of these new pickups are considered as a whole, it is evident that the service-dealer has a rare opportunity knocking at his door. First and foremost is the potential consumer business to be had. The argument for these new pickups is so convincing that the average consumer should be a push-over. The convenience of not having to change needles, coupled with the economy of record preservation is reason enough, without even considering the improvement that may be had in record reproduction. Secondly, record shops, confronted with the problem of how to prevent the damage of records by customers who play them in the store, will find the answer in these pickups. Some makes are so designed that the pickup can be dropped onto the record surface without doing damage to either the record or the needle.

The improvements outlined have been brought about principally by reducing the needle pressure. Whereas previous designs had a needle pressure of three or more ounces, the new pickups impress a weight on the needle of only an ounce or so. Coupled with this low pressure is a reduction in the stiffness of the moving parts and the use of considerably less mass which decreases over-all inertia of the moving elements. The mechanism is therefore more responsive to induced vibrations of a higher frequency, and the reduction in mass places the resonance point of the moving element outside of the highest frequency reproduced. The



The Audax Pro-5 Relayed-Flux Microdynamic magnetic pick-up with removable sapphire stylus.

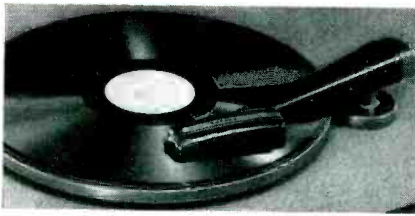

The Brush PL-25 crystal pickup with built-in sapphire stylus. Needle pressure, 30 grams.

decrease in mass and stiffness of the actuating mechanism with relation to the mass and weight of the pickup arm has served to reduce needle and arm "talk" to a negligible quantity. Hence, many of the new pickups can be used on open turntables without causing interference.

PICKUPS AVAILABLE

Pickups of this type are being marketed by Astatic, Audak, Brush and Shure. The Astatic and Brush pickups employ permanent sapphire needles built into the cartridges. The Audak and Shure pickups are designed for use with removable needles of either the regular or long-playing type. Some are equipped with a small, slotted screw in the needle chuck for semi-permanent needle installation; others are supplied with the slotted screw and a thumb screw, either of which may be used.

Available from Astatic are Models FP-18 and FP-38, both having one-ounce needle pressure. Model FP-18 has a frequency range of 30 to 7000 cycles and is intended for use on commercial records. Model FP-38 has a frequency range of 30 to 10,000 cycles, and is designed for high-fidelity applications. Though the output voltage available

from the FP-38 is less than that from the FP-18, both are applicable to the audio amplifier found in the average phono-radio combination. The sapphire stylus in each model is piano-wire coupled to the crystal, is spring-mounted, and protected by a U-guard.

Available from Audak are the Audax Microdyne magnetic pickups. Models D-37-E and D-36-E have a needle pressure of 39 grams, may be used with jewel points, and have a response out to 7500 cycles, with a rising bass curve reaching about 8 db at 50 cycles. This bass rise, to make up for the bass deficiency on commercial records, is gained by internal compensation. The Relayed-Flux Microdyne Model PRO-5 has a needle pressure of 25 grains and is substantially flat out to 10,000 cycles. A built-in sapphire needle is employed, but this may be removed in case of an emergency and the pickup operated from a conventional steel needle.

Available from Brush are the PL-20, PL-25 and PL-50 crystal pickups with built-in sapphire styli. These pickups also employ piano-wire coupling between the jewel point and crystal element. Both the PL-20 and PL-50 are substantially flat out to 10,000 cycles, but the output of the PL-50—the more expensive of the two—is not sufficient to drive the average low-gain audio amplifier. The PL-50 has a stylus pressure of 15 grams; the PL-20 a pressure of 30 grams. The PL-25 is similar to the PL-20, but has a shorter arm.

Available from Shure are the Models 994A and 999C crystal pickups, the latter being a new version of the "Zephyr". Both have a needle pressure of $1\frac{1}{8}$ ounces, (as against a previous $2\frac{3}{4}$ ounces) employ the "balanced-tracking"

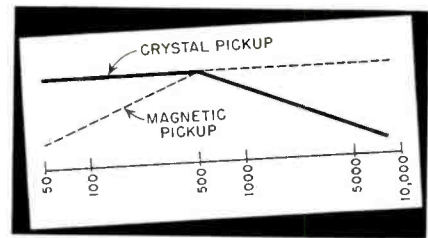

Fig. 2. Characteristics of crystal and magnetic pickups with relation to commercial record characteristics.

principle, and are designed for use with any type needle. Semi-permanent needle installation can be made by means of a slotted screw. Voltage output of either type is sufficient for even a low-gain amplifier.

INSTALLATION FACTORS

With the exception of the Brush PL-50, all of the aforementioned pickups can be used in place of standard pickups, without any circuit changes. In the case of the crystal pickups, however, and particularly those employing piano-wire coupling, the full advantages cannot be derived without some form of equalization or frequency compensation.

If the customer is to derive the greatest benefit from one of these new pickups, there are a number of points to be considered prior to installation. The first point is that there is nothing to be gained by equipping the system—pickup, amplifier and speaker—to reproduce anything

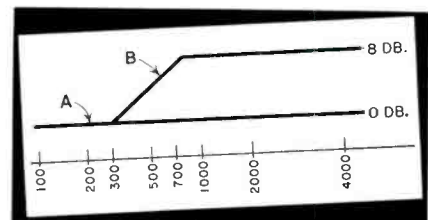

Fig. 3. Curve B shows result of improper compensation for transition frequency.

beyond 7500 cycles at the most, for anything on the record above that frequency is surface noise. By the same token, there is nothing to be gained by adjusting the pickup load circuit for response to even 7500 cycles if the amplifier and speaker involved haven't an equivalent range. Moreover, if the turntable is none too good, either sell the customer on the idea of buying a new one, or plan to curtail somewhat the extended low-frequency response of the new pickup to avoid the reproduction of turntable rumble.

Assume the pickup response to be similar to that shown at A in Fig. 1. It is evident from this curve that, if there is no cutoff, surface noise will be considerably increased by virtue of the peak above 5000 cycles. It is also evident that, unless the turntable is a good one, there is apt to be an annoying rumble repro-

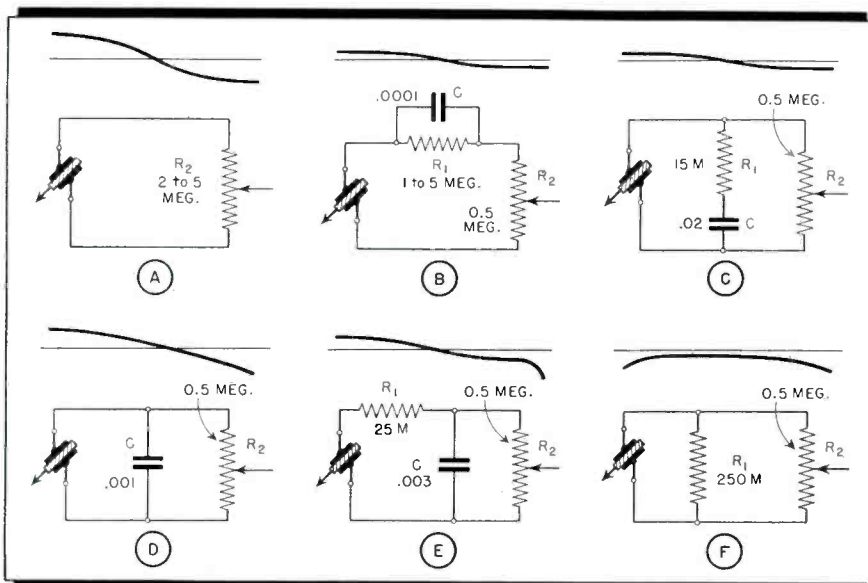

Fig. 4. Pickup circuits for obtaining characteristics similar to those shown above each diagram. Values given are variable over wide limits.

duced through the system by virtue of the comparatively high bass response of the pickup below 50 cycles where the rumble is present. Hence, the system could be cleared up considerably by adjusting the pickup circuit to reproduce only the range from points 1 to 2, or 50 to 5000 cycles.

The peak in the mid-range would also have to be eliminated, which is readily accomplished by equalization. The presence of such a peak would naturally serve to emphasize certain frequencies, giving a harsh, shrill tone, and also mask other frequencies. If frequency masking is present, the instruments of an orches-

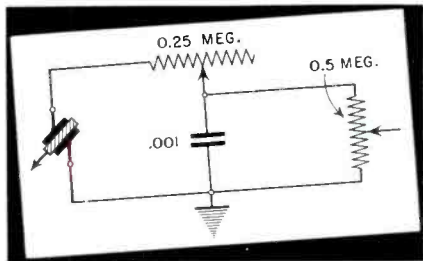

Fig. 5. Simple tone-control circuit for reducing needle scratch, yet providing full range when desired.

tra, for instance, will blur together. If the masking is particularly bad, certain instruments of the orchestra will not be heard at all.

Equalization eliminates this difficulty as well, as shown at B in Fig. 1. But, though the response curve of the pickup has been made substantially flat, there is still nothing to be gained by reproducing any frequencies below point 1 and above point 2 unless the audio equipment is first-rate.

This does not mean, however, that nothing is to be gained from the use of a wide-range pickup even though the reproduced range is to be no more than 50 to 5000 cycles. The reason for this is two-fold: First, the pickups designed for a range of 30 to 10,000 cycles have a more even response through the entire range when properly equalized than do the others. Second, the wide-range pickups have the least amount of inertia or vibratory momentum and therefore have a lower factor of harmonic distortion. In turn, these pickups have a lower voltage output, but, with the one exception mentioned, are satisfactory for driving the average amplifier.

FREQUENCY COMPENSATION

The need for some form of compensation in either the magnetic or crystal type of pickup is due to the characteristics of commercial records. It is practice to record a constant amplitude cut up to a frequency of 300 or 800 cycles, and cut constant velocity above that point. Since a magnetic pickup produces a voltage

which is proportional to stylus *velocity*, and the crystal pickup produces a voltage which is proportional to stylus *amplitude*, the first type has a rising characteristic with relation to the recording, whereas the second type has a drooping characteristic, as shown in Fig. 2. Hence, if the final response is to be flat, the magnetic pickup requires bass boost and the crystal pickup requires high-frequency boost, or, what amounts to the same thing, a reduction of bass response to a point where it equals the high-frequency response.

The need for a variable factor in the over-all response of the record-reproducing equipment is dictated by the fact that the frequency characteristics of commercial records are not standardized. The so-called "turnover" or "transition" frequency—where cutting departs from constant amplitude to constant velocity—may be at 300 cycles on some records and at 800 cycles on others. Moreover, in some cases there is a second transition point somewhere between 1000 and 3000

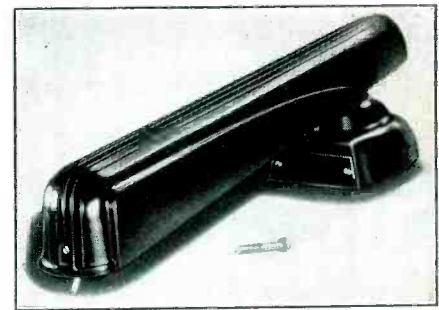

Shure type 999C low-pressure crystal pickup with slotted screw and thumb screw.

cycles. Hence, for best results, the response of the reproducer should be constantly variable or variable in steps to compensate for differing record characteristics.

The discrepancy that may result from improper compensation is effectively demonstrated in the curve of Fig. 3. This shows the results of playing a record with a transition frequency of 800 (Turn to page 25)

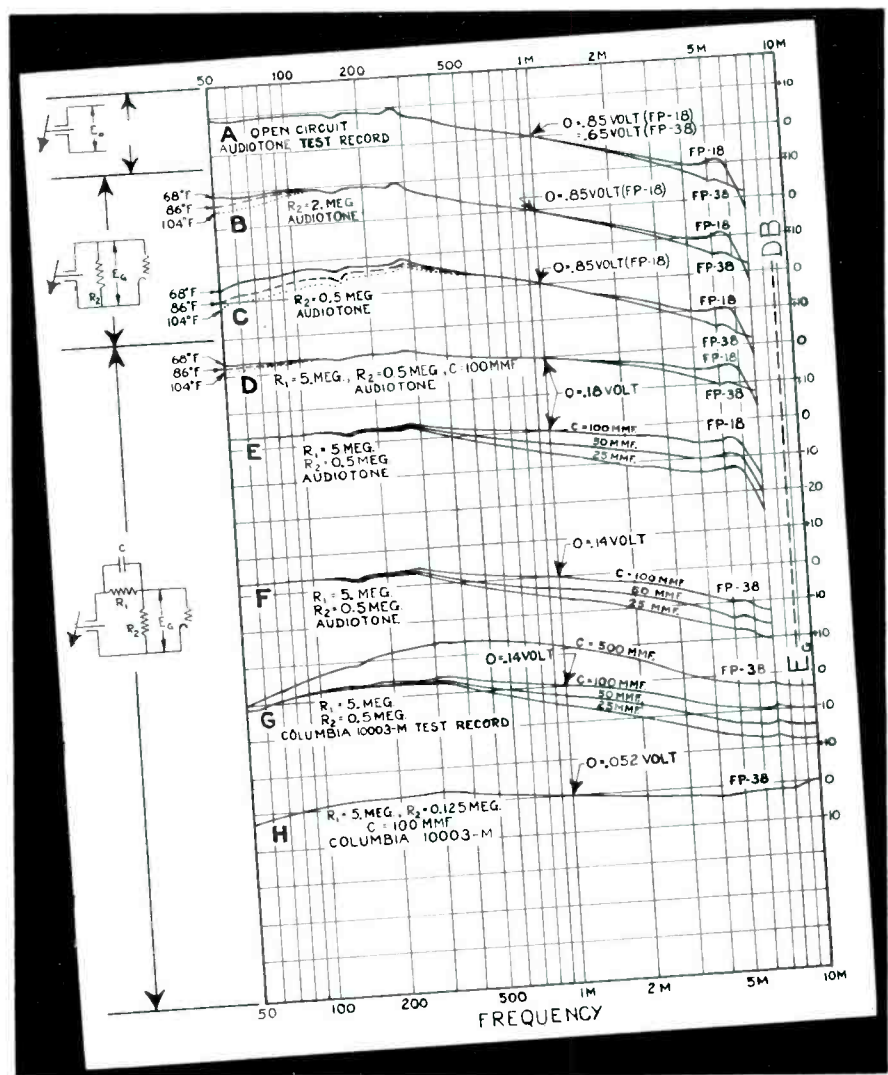

Fig. 6. Characteristic curves of Astatic FP-18 and FP-38 crystal pickups with various values of resistance and capacitance in the compensation networks. Note that the use of a series equalizer (curves D) reduces the effect of crystal temperature on frequency.

RADIO'S MOVING DAY

THE Federal Communications Commission on January 31st gave final approval to the Recommendations of the Engineering Conference, just concluded at Washington, D. C., under the North American Regional Broadcasting Agreement, Habana, 1937, and released the revised list of United States frequency assignments which will become effective at 3 a.m., Eastern Standard Time, on March 29th.

Under the agreed allocation, 795 of the 883 standard broadcast stations in this country will begin operation on the new frequency assignments at the time specified.

Here, in general, is how the domestic shift will be accomplished:

Stations now operating on channels of from 550 to 720 kc will retain their present assignments.

Stations operating between 740 and 780 kc will move up 10 kc, or one channel.

Stations between 790 and 870 kc will move up 20 kc, or two channels.

Stations between 880 and 1450 kc will generally advance 30 kc, or three channels.

Clear-channel stations will shift from 1460-1490 kc to 1500-1530 kc.

Local stations now on 1500 kc will move down one channel to 1490 kc.

YOUR JOB

There are approximately 10 million push-button receivers in operation in this country. It will be your job to re-set the buttons for the new frequencies in the shortest possible time and with the least amount of confusion. It will also be your job and your opportunity to inspect these receivers for faulty operation. No such opportunity is likely to present itself again, so make the best of it.

There is another angle to this that we wish to stress. Many customers are going to view the broadcast-station moving day in the wrong light, if they are not given a proper explanation as to why station frequencies are being reallocated. There are bound to be listeners who will form the opinion that "the whole business is just another stunt to make money out of the public." None of us want anything of that sort to happen. Therefore we urge you to correct any such impressions that may form in the minds of your customers.

You know, of course, that the reallocation program is a good thing for the public—that station interference will be materially reduced once the broadcast stations take up their new homes in the standard band. Explain to customers

Reallocation of Broadcast Frequencies March 29th Opens Big Job For Servicemen Resetting Nation's Push-Buttons

who may ask for the reason that five governments have spent three years working out this plan whereby the 1300 broadcast stations in the North American region may occupy the ether without causing interference with one another, as many of them have in the past. The change will bring vastly improved reception to the majority of the public, and particularly to those listeners located some distance from the regular stations.

Moreover, the broadcasters have a definite interest in the coming change. It is their continual aim to provide the very best in program presentation that the art permits, and to this extent have spent millions of dollars annually on new equipment. But their ability to provide the very best reception is limited by the condition of each receiver they serve. Poor reception is something over which the broadcaster has no direct control.

It is natural, therefore, that the broadcasters see in the reallocation program a golden opportunity for the rehabilitation of receivers and antenna systems that have jointly or in combination undone so much of the good the broadcasters have built up.

Only the serviceman can grasp this opportunity for the broadcasters and really make something of it. In this instance, then, you will aid not only yourself, but the entire radio broadcast field, by making it a point when Moving Day rolls around, to inspect all receivers while you are re-setting the station buttons. If you run into any of the usual faults, such as noisy reception, distortion, poor tone, blasting or inadequate selectivity, advise the owner and strongly suggest repair or reconditioning.

PLAN NOW

With 10 million receivers to be re-set, servicemen will have their hands full. Your problem will be how to re-set the greatest number of receivers in the shortest possible time and at a moderate cost to the customer. The best answer to the problem is to start making plans now. Here are some suggestions:

If you haven't a radio set census of your territory, start working up a list of push-button set owners, with make and model of receiver in each case. Check the names of your steady customers on this list, and count on serving them first. They'll expect it of you, and if you slight 'em, the fellow around

the corner may pull a snatch—for keeps.

Arrange your list into sections, blocks or streets so as to reduce waste motion in your rounds when Moving Day hits the town. Don't dash madly from one end of town to the other and then back again or you'll eat up all your profits in lost time.

Go through your Manuals and earmark for segregation and study the button re-setting dope on all the receiver makes and models in your customer list. You'll waste good time if you put off reference to this data until you are on the job.

Contact all your regular push-button customers beforehand; advise them of the proposed channel shifts and try sewing them up for the re-setting job. Attempt to arrange a definite appointment for the day the shift is to take place. Follow up by contacting the remainder of the list, with the same idea in mind.

When the time arrives, keep someone glued to the office phone and call back periodically to pick up service calls. Also let the "office" work on your list by phoning prospective customers in the section in which you are working. Or take someone with you to push bells while you're occupied.

RE-SET CHARGES

It would seem logical for servicemen to establish a "per button" re-set charge, graduated in accordance with the type of automatic tuning involved and the complexity or simplicity of re-setting a position. You should be able to determine a fair figure for each case on the basis of past work of the same nature.

Most listeners will give first consideration to home receivers. Whether servicemen should attempt the re-setting of auto receivers while doing the home sets will depend upon circumstances. If it turns out that you're as busy as a doctor in a flue epidemic, get the home receivers done first and handle the auto jobs afterwards. On the other hand, if it turns out that you haven't too many calls to make, do both jobs at the same time and save yourself a second trip to and from the customer's home.

It's too early to forecast conditions as they may be, but it appears that Moving Day is going to take on all the aspects of a first-class emergency. You've got to be prepared for an avalanche in any event.

Another

RAYTHEON TUBE EQUIPPED SCIENTIFIC CREATION

THE SMITH ARC-LENGTH MONITOR WELDING CONTROL

The Arc-Length Monitor, developed by A. O. Smith Corporation, is a modern production tool which guides the arc-welder to make uniformly sound and perfect welds.

Tiny electric bulbs inside the welder's shield automatically warn the operator when his arc is too long or too short. The glows of the bulbs increase in brightness as the welder deviates from the correct arc length. Only when the arc is of proper length for the job—i. e., making a good weld—are both the lights off.

An intricate electronic circuit, using six RAYTHEON tubes, is the brains of this device, which is made by the RAYTHEON Equipment Division for the A. O. Smith Corporation.

It is not a coincidence that when radio tubes are used in particularly critical circuits you find them to be RAYTHEONS. And they are the same tubes the better Servicemen use as replacements. There is no finer quality, yet they cost no more.

Your RAYTHEON Distributor has an unusual tube deal for you. See him without delay.

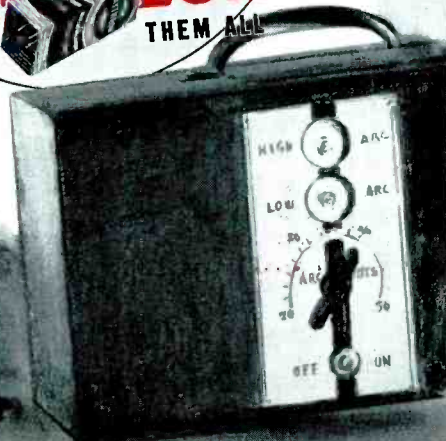
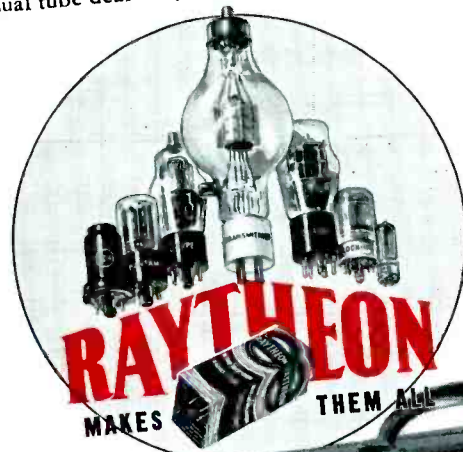

WORLD'S LARGEST EXCLUSIVE RADIO TUBE MANUFACTURERS

RADIO SERVICE-DEALER, FEBRUARY, 1941



Did You Know

—that the organs of the human body are so closely inter-related that disease or breakdown in one organ may well affect other organs unless given immediate medical care?

—that the parts of a radio receiver are also closely inter-related, and the deterioration or failure of one part may well affect other parts unless immediately repaired?

★

—that the complexity of the average radio receiver—both as to the number of its parts or "organs" and its operation—is on a par with the functional intricacy of the human anatomy?

★

—that there is such a marked similarity in the symptoms of a multitude of human illnesses that only a doctor of proven competence can make a correct diagnosis and administer the proper curative?

—that there is such a marked similarity in the symptoms of a multitude of radio-receiver "illnesses" that only the technically-trained, experienced serviceman can make a correct diagnosis and undertake the proper repairs?

★

—that a doctor, if given the opportunity, can detect an incipient illness long before it has any marked effect on the patient?

—that a competent serviceman, if given the opportunity, can detect a fault in a radio long before it has done damage and before the owner realizes anything is fundamentally wrong?

—that your chances of enjoying good health are immeasurably improved if you submit yourself to a periodical examination by your doctor and dentist?

—that your chance of enjoying consistently good radio reception and of preventing major breakdowns are immeasurably improved if you have your receiver checked periodically by a competent, well-established radio serviceman?

★

—that the ability of a competent, well-established doctor rests in his training, his practical experience and the equipment provided him by science without which he could not detect numerous functional disorders?

—that the ability of a competent, well-established radio serviceman rests in his training, his practical experience and the equipment provided him by science without which he could not detect numerous faults in a radio receiver?

★

Your Doctor Knows Best—
So Does Your Radio Serviceman

S. R. Lowan Publisher

Radio

SERVICE-DEALER

THE LEADING SERVICEMEN'S MAGAZINE



CONDITIONING THE CONSUMER

NOW that the first phase of our campaign to improve the lot of the accredited Service-Dealer is well under way, and the Certification Seals are becoming prominent throughout the nation, it is time to enter the second phase of the campaign.

This second phase, which is intended to work hand-in-hand with the first, will take the form of an educational campaign directed to the set owner. The main purpose of our efforts in this respect will be to improve public relations; that is, to educate the average set owner to an understanding of the trials and problems of servicing, and how he, as a consumer, can best be served. In order to accomplish this purpose, we will publish a series of placards with sufficient novelty to attract the eye.

As each placard appears, we suggest that you cut it out of the magazine and display it in your store window, or on a wall of your shop where it can be readily seen and read. If you do not wish to cut up your copy of **RADIO SERVICE DEALER**, a single two-color reprint of the same size can be obtained directly from us for the sum of 10 cents. They will be mailed flat. Prices on quantity orders will be quoted on request for those who may wish to mail copies of the placards to their customers.

The first placard of the series is reproduced on the opposite page. Help the servicing business—and yourself—by making use of it or a reprint, as mentioned above.

PUBLIC RELATIONS

In any campaign to improve public relations, it is just as essential that the profession represented in the campaign live up to its own ethics as it is to build up public confidence. There is little point in teaching the set owner that "Your Service-Dealer Knows Best" if his service-dealer turns right around and pulls a boner or oversteps the line of professional etiquette. Yet this is what happens daily in the servicing field.

In the retailing business, the by-word is, "The customer is always right." We know, of course, that the customer isn't always right. We know that he seldom is right, but he must be *treated* as though he were. He's spending the money and, right or wrong, he'll be treated right or go elsewhere. That is the cross every retailer must bear—and every servicer, too.

Every serviceman has nasty customers to deal with, to say nothing of the type

RSD's New Educational Campaign to Improve Serviceman-Consumer Relations and Protect the Full-Timer

of customer who knows better than the expert what should have been done rather than what was done. And certainly, there is no serviceman who has not heard directly or indirectly that old customer complaint, "The set worked better before any work was done on it."

But remember this: A customer may be nasty because of a past grievance that grew out of a real or imagined rough deal on your part or the part of some other serviceman. The fellow who knows better than the expert may well have arrived at such a conclusion by virtue of the damnfoolishness of some other serviceman. As for the customer who is convinced that the set worked better before you "fiddled" with it—the chances are good that he may be partially right in his viewpoint. You may have oversold him on the results to be expected from a minor repair; you may have overlooked a secondary fault that contributed equally to poor operation; or you may have permitted the customer to talk you out of extensive repairs when they were actually necessary. Again, as often happens, some part other than the one you replaced may have subsequently failed, which is not exactly your fault, but neither is it the fault of the customer.

HOW TO FAIL

The thing to do is to make sure that you are as right as you can be—and when you *are* in the wrong, take it with good grace and assume the responsibility. If you have insured yourself against being wrong, a full explanation to an irate customer will more than likely satisfy

him in the end. But insure yourself to such a degree that there can be no misunderstandings.

A few true cases will serve to illustrate the point. The first case has nothing to do with radio, but you will find a parallel in it with no difficulty. It is Lesson No. 1 in how to fail.

A woman had the radiator of the family car drained, flushed, and refilled with water and anti-freeze alcohol at her regular service station. She returned for the car after a local visit, started for town, and after driving a short distance noted that the radiator was steaming like a tea kettle. She drove on until she reached another service station, where it was found that no water had been put in with the anti-freeze liquid.

She stopped at the regular service station on the way home and complained of the incident. They remembered, then, that one of them had put in the anti-freeze and the other was supposed to have put in the water, but just then someone wanted gas and he had forgotten. They thought it rather a good joke.

The woman asked what was to be done about the anti-freeze that had steamed off, and they assured her that the amount lost would have been negligible and she needn't worry. She accepted their word for it. A week later there was a real cold spell and the car froze up . . . all for the want of a bit more anti-freeze.

Naturally the error was excusable—we all make mistakes occasionally. But the lack of responsibility was not excusable. Possibly the operators of the serv-

(Turn to page 26)

George C. Conner, Sylvania Commercial Engineer, in graph form and with circuit diagrams chalks up the solutions to radio servicing problems that can be translated into profit dollars for servicemen of Oakland, California.

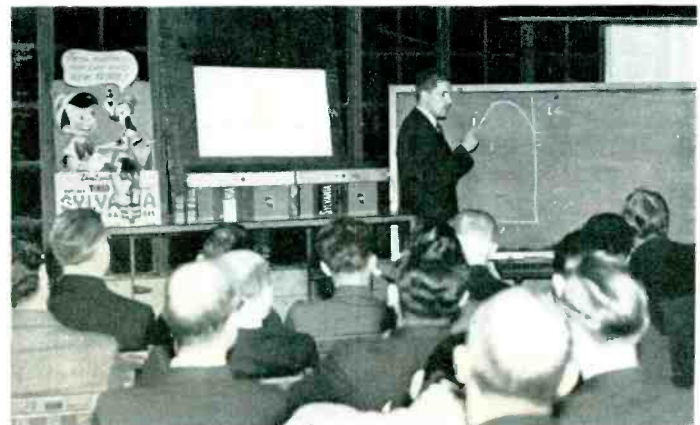

Set of the Month—

MOTOROLA MODEL 35-F AUTO RADIO

THE Motorola Model 35-F is specifically designed for installation in the 1941 Ford and Mercury cars. It employs six tubes, one of which functions in a tuned r-f stage. High gain iron-core coils are used in the i-f stage and the antenna circuit.

It will be noted from the circuit of Model 35-F on the opposite page that coupling between antenna and r-f coil is capacitive, the voltage being developed across the 600-mmfd padding condenser. Capacitive coupling is also used in the r-f transformer.

Control bias is applied to the r-f, modulator and i-f tubes. Several values of fixed bias are developed across the resistors 43, 44 and 40 in series with the negative leg of the power supply. A negative bias of 2.8 volts appears across resistor 43 and is applied to the cathode of the 6SQ7GT. This fixed voltage is also applied to the avc line and therefore serves as an initial bias for the r-f and modulator tube. The i-f tube is cathode biased by resistor 37 which places the cathode at a positive potential of 7 volts above ground. But, the grid is at 2.8 volts negative. Hence, the effective bias on the 6SK7 grid is 4.2 volts.

Bias for the grid of the 6U6GT developed across resistors 43 and 44, but since the cathode of this tube is 2.8 volts negative with respect to ground—by virtue of the drop across resistor 43—the effective bias on the grid is equal to the drop across resistor 44 only.

Bias for the grid of the 6U6GT power tube is the total voltage developed across resistors 43, 44 and 40.

Note that a triple-function mica condenser is used in the secondary circuit of the diode i-f transformer. One section of this stacked condenser is adjustable and functions as the secondary trimmer. The remaining sections are

Average Microwatt Input*	Generator Set At	Generator Feeder Connected To	Dummy Antenna Capacity	Leak Resistance	Output Meter Reading**
22,250	262 kc	I.F. Grid	.1 mfd	5 meg	1.74
700	262 kc	Mod. Grid	.1 mfd	.5 meg	1.74
710	600 kc	Mod. Grid	.1 mfd	.5 meg	1.74
13	600 kc	R.F. Grid	.1 mfd	.5 meg	1.74
3	600 kc	Ant. Lead	***	None	1.74

Volume Control Set at Maximum
* 1 Watt = 1.74 Volts

Tone Control Set At Voice
** Output meter connected across voice coil.
*** Use Special Dummy Part No. 1X26767 or Booster Coil Part No. 24K26751 in series with a 35 mmfd. condenser.

fixed and, in conjunction with the 470,000-ohm resistor, form the i-f filter. Both the triple condenser and the resistor are contained in the i-f transformer shield, as indicated by the dotted lines.

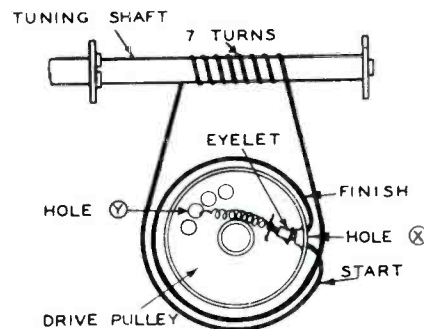

Fig. 1. Method of restringing broken tuning cord.

A resistance-capacity filter is employed in the power-supply circuit. This consists of two sections of the triple-section electrolytic condenser 15 and the 1000-ohm resistor 38. The plate of the 6U6 power tube is fed directly from the

cathode of the 6X5GT rectifier. This is permissible since a small degree of ripple voltage on the plate of a power pentode or beam-power tube does not cause a corresponding change in plate current.

The screen of the power tube and the remainder of the tubes in the receiver circuit obtain voltage from the output of the filter of which the 200-volt electrolytics are a part. The 25-volt electrolytic bypasses the bias resistors 43, 44 and 40.

SERVICING

Voltage readings, chassis layout and points of adjustment are shown directly below the schematic diagram. Complete alignment data is given in Table I. Sensitivity and stage gain measurements are provided in Table II.

In the event of tuning cord breakage, remove chassis from housing and place on service bench. Remove the broken cord and turn gang condenser to fully meshed position. Cut a length of 30 lb. silk fish cord 25 inches long and thread one end of the cord through hole X (Fig. 1) in drive pulley, and with an ordinary paper clip fasten to tuning control bracket so that cord will stay in place. Then wind cord one-half turn, in a clockwise direction, around drive pulley and up to tuning shaft. Continue by routing cord 7 turns around tuning shaft and down to drive pulley, as shown in Fig. 1. Continue in a clockwise direction, one full turn to hole X.

Thread cord ends (inside pulley) through eyelet and knot cord ends together. Fasten one end of spring to cord and the other end to hole Y in drive pulley. Cut off surplus cord and place a drop of shellac on cord knot.

In the event of a broken pointer cord,
(Turn to page 30)

TABLE I

Operations In Order	Gang Condenser Set At	Dummy Antenna Capacity	Generator Connected To	Adjust Trimmers No.	Generator Set At
1	Minimum	.1 mfd	Osc.-Mod. Grid	1-2-3-4	262 kc
2	1600 kc	.1 mfd	Osc.-Mod. Grid	5	1600 kc
3	545 kc	.1 mfd	Osc.-Mod. Grid	6	545 kc
4	1400 kc	*	Special Dummy	7	1400 kc
5	1400 kc	*	Special Dummy	8	1400 kc
6	600 kc	*	Special Dummy	9	600 kc

* Use special dummy Part No. 1X26767 or Booster Coil Part No. 24K26751 in series with a 35 mmfd. condenser.

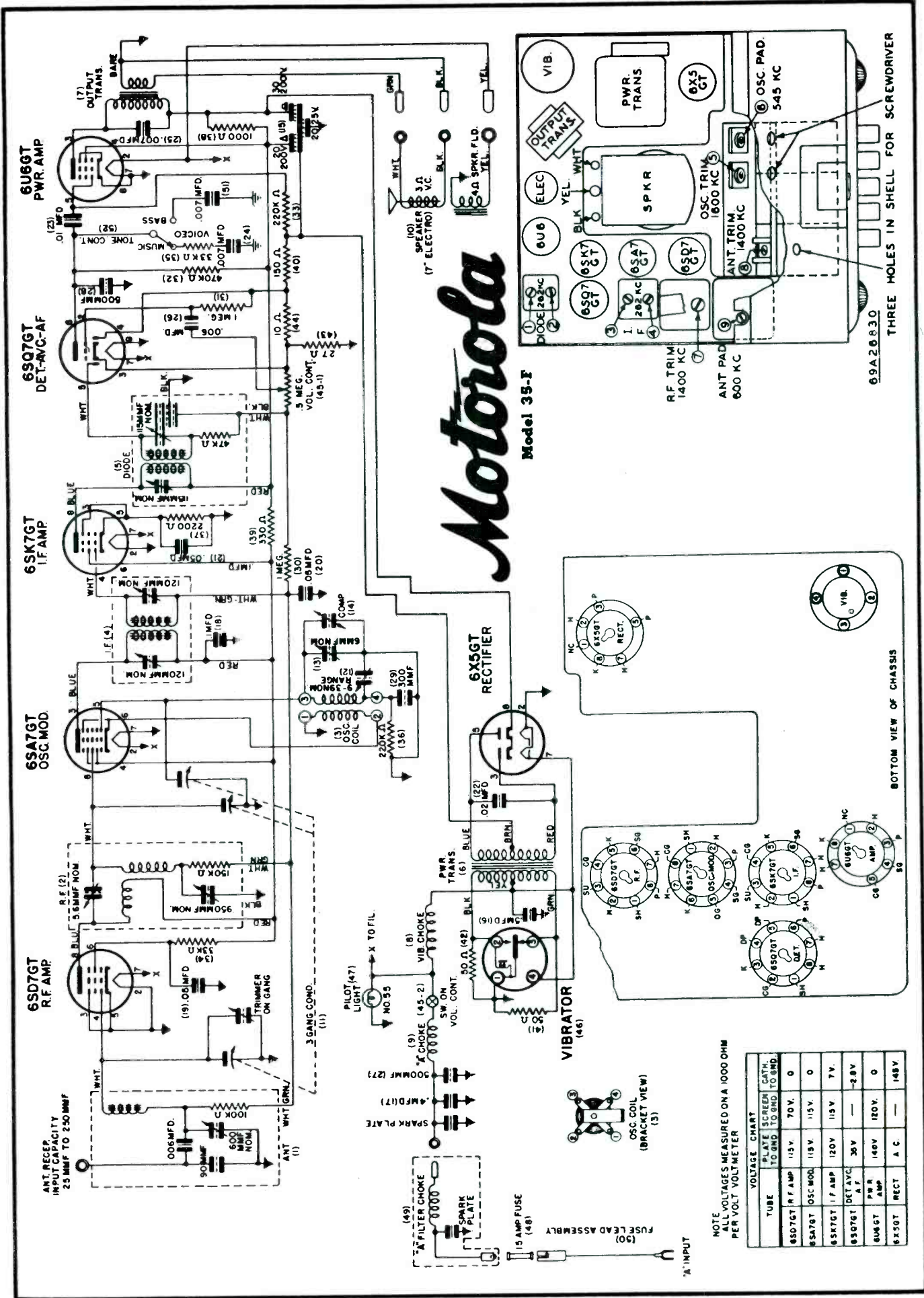

Motorola

Model 35-F

NOTE: ALL VOLTAGES MEASURED ON A 1000 OHM PER VOLT VOLTMETER

TUBE	PLATE	SCREEN	CATH. TO GND.
6SD7GT	115 V	70 V	0
6SA7GT	115 V	115 V	0
6SK7GT	120 V	115 V	7 V
6U6GT	140 V	120 V	0
6X5GT	140 V	140 V	0

THREE HOLES IN SHELL FOR SCREWDRIVER

BOTTOM VIEW OF CHASSIS

SALES HINTS FOR SERVICERS

THE radio servicing profession will probably never be a Utopia. It will never be a perfect business in every sense of the word for the simple reason that there will always be a part-time serviceman around the corner ready and willing—and how—to accommodate the pound-foolish set owners at a “reduced rate.” There will always be a parts jobber willing to sell at “trade discounts” to anyone who will lay cash on the line. Moreover, there will always be a few parts jobbers doing a bit of “retail servicing” on the side, in direct competition with their regular serviceman and dealer customers. These are conditions we can never wholly escape.

But to say that the conditions cannot be improved is to be unduly pessimistic. There are forces of good as well as evil, and there are many radio servicemen's associations that were organized for the prime purpose of fighting the evils that do exist in the field. It is wise policy for service-dealers to join such associations, for in unity there is strength—which is an axiom that many service-dealers have failed to appreciate.

CREATING OPPORTUNITY

In the meantime, the practical service-dealer must justify his existence by seeking the means whereby he can survive and prosper. To do this he must sell, sell, *sell*, for it is only through selling that he can create opportunities. He

Third of a Series on the Certified Service-Dealer Plan

must, first of all, sell his primary services in the best way he knows—and in this he must command and obtain decent payment. But, beyond this, he must make his prime business serve as a lever to pry up the sale of radio merchandise to his regular customers. He must, to put it briefly, find ways and means of getting at this potential business.

This may all sound like arm-chair preaching, but it is nothing of the sort. It is a report on facts, and the moral of the report is that any business is doomed that is permitted to roll along on its own momentum. There is, after all, no such thing as perpetual motion.

FRUIT TO PICK

In previous issues of RADIO SERVICE-DEALER, we have described how to make money by refinishing and touching up damaged or scratched receiver cabinets; how to put a bit of showmanship in the testing of equipment, with the purpose in mind of selling a customer on a better phono motor or pickup; selling phono needles, recording styli and record blanks, etc., on the basis of your own ability to best answer a customer's technical problems and questions. And how simple it is to make call-backs on little-heard-from customers without making a nuisance of yourself. What

other ideas are there? Plenty! One first-rate plan that has proven itself is the basis for a separate article in this issue. And to follow are some stunts that have been tried and found to be profitable.

Very little can be sold until it is shown to the prospective buyer. It is logical, therefore, to stage a “preview” whenever the opportunity affords itself. And that's just what one enterprising service-dealer did with a microphone and a record player. Since he hit it cold, it is an interesting story in itself.

He had not heard from the customer for quite some time, so he took a chance on a call-back, using the “It's part of our routine check-up” approach. It got him in, and it got him the sale of two tubes that were on their way west—one in an RCA console job and another in one of two ac-dc sets used in the kitchen and a bedroom. But that was nothing.

This service-dealer had a high-impedance mike and a good record player with him. Also an album with some Red Seal recordings of the Boston Pops Orchestra—swell platters for demonstrating what modern phonograph reproduction can really be.

His first “act” was to plug the mike into the phono jack and, from off to one side to prevent feedback, repeat the stock “One, two, three, four—testing.” This brought the family running to see what was up. He explained to them that he was using the console set as a public-address system merely to test its fidelity, but remarked—now that he had his audience—that he would prefer an actual test with a record player, with their permission.

Their permission! He couldn't have held them with horses, since they had never heard phonograph music through their own “machine.” He played those Boston Pops records, and at the termination of the “concert” calmly told them that the audio system in their receiver was okay—and started to pack up.

Did he get out without questions? He did not. They held him there and discussed record players, pickups and prices—and when they could get delivery.

He didn't sell 'em a mike, but he didn't intend to—that was the come-on. But he did sell them a self-contained automatic record player for the con-

(Turn to page 29)



THE WINNERS—Sam Macdonald, Shure Brothers' rep., presenting a loving cup to John Stern, of Radio Electric Service Company, Philadelphia, who took first place in the Shure All-Star Football Game Contest. A cash prize was also given. From left to right are, Jim Faries, salesman for S. K. Macdonald; S. K. Macdonald; John Stern, Gene Rothman, and Morris Green. George D. Barbey Company, Reading, Pa., took second place.

TECHNICAL SERVICE PORTFOLIO

SECTION VIII

HIGH-FIDELITY RECEIVERS

THE first question which confronts us in discussing this topic is just how a high-fidelity receiver differs from other high-grade console broadcast receivers. As it happens, this is not easy to answer because no definite standards for high-fidelity performance have ever been established.

A great many important considerations enter into high-fidelity performance; many of which are seldom discussed. As a result, there are many misconceptions in the field. Too often, emphasis has been laid only on the broad frequency range required for high-fidelity reproduction and the flatness of the response through the various *amplifier stages* of the receiver. Yet, as we shall see, flat amplifier response may be definitely undesirable. And, unless the wide frequency range is accompanied by *correspondingly reduced distortion*, it is possible that the performance of a so-called high-fidelity receiver may be inferior to that of a less aristocratic instrument. Further, unless a high-fidelity receiver is properly installed—and a good installation means a good aerial—the results secured may be distinctly unsatisfactory. The fact that the general public has not gone for high-fidelity receivers in a big way is not due to a preponderance of “tin ears” among the gentry, but simply because the performance has not been as good as they have been led to believe it should be.

RECEIVER CHARACTERISTICS

It is generally agreed that high-fidelity receivers should possess certain minimum qualifications. For amplitude modulation receivers, the frequency range of from 50 to about 8000 cycles should be reproduced fairly uniformly, within about plus

or minus 5 db. A wider range could be obtained, but there would be little point in doing so as long as the frequency allocations of major stations are so close that adjacent channel interference in the form of “monkey chatter” results at 10 kc when a 20-kc channel is employed. For frequency modulation, the frequency range is increased to 15,000 cycles at the high-frequency end and, to preserve the proper acoustic balance, the low-frequency response range is proportionately increased to include 25 or 30 cycles. Uniform response is not desired over the high-frequency portion of the range, because the high frequencies are purposely emphasized at the transmitter in order to over-ride the noise so prevalent at such frequencies. Accordingly, means are provided in the f-m receiver to reduce the highs to the normal level—thereby reducing the noise in like proportion—usually by means of a filter or “de-emphasizer” in the output circuit of the discriminator-detector. Another advantage thus secured is an attenuation

of the harmonic distortion which develops in the discriminator. Insofar as the overall response of the f-m receiver is concerned, it will normally show considerable attenuation of high frequencies when checked with a test oscillator at a point which includes the high-frequency filter. No matter which type of receiver is used, the object is to secure uniform “output” response over a wide frequency range.

Maximum undistorted output from the a-f amplifier is preferably at least 20 watts for high-fidelity receivers. By “undistorted” it is meant that the harmonic distortion does not exceed 5%. For lower output power levels, the distortion should be considerably less. The reason such a relatively high amount of distortion as 5% is considered permissible at maximum rated undistorted output is because it is assumed that this high level will be reached only momentarily on peaks of very short duration and, consequently, should not prove annoying.

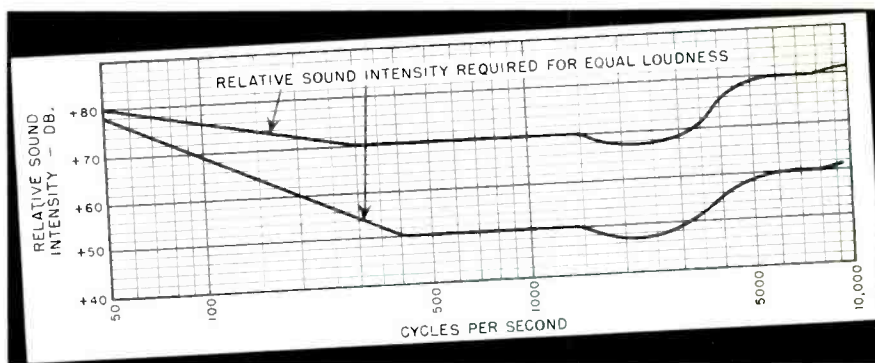

Fig. 1. Chart showing the relative loudness of various tones required for faithful reproduction.

FREQUENCY-VOLUME LEVELS

So we see that the aim in high-fidelity receivers is to reproduce as nearly as possible the original sound. This seems reasonable if the sound being broadcast is a human voice, since then the source of the sound is almost a single point and the sound intensity is not too great for an ordinary room. If the broadcast transmitter sends out a wave which includes in its modulation all the components of the voice of the speaker, each in proper degree, and the receiver reproduces these sounds at the original voice level, it should be impossible to distinguish between the two. In the case of a violin, or a musical instrument of similar acoustic power output, the same condition holds.

For orchestras and bands, however, the problems of high-fidelity reproduction are vastly more complex. In the first place, our problem is no longer to reproduce at the same volume as that existing at the concert hall. Even if we wanted to do so, that would be impossible with a home receiver, for the peak acoustic power reached by an orchestra may come to 100 watts, which would require a 400-watt amplifier at the receiver for exact reproduction. And, of course, no one would want so much sound volume in a living room. Again, the acoustics of a living room differ from those of a concert hall, so even an exact reproduction at the same relative sound level as would be experienced by a listener seated in a concert hall would not sound the same in a living room.

In a quiet room, the sound need not be so loud as in a relatively noisy room, if the program is to be heard and enjoyed. Yet—and this is important—any change whatsoever in output sound level from the loudspeaker causes an alteration in the relative loudness of the various tones, so that the reproduced program sounds different at one sound level than it does at either a higher or lower level; that is, a very small change in sound in-

tensity may cause a much greater change in the actual loudness of the sound at one frequency than it does at another.

This is shown in Fig. 1. Note that from about 300 to 3000 cycles, at a sound level of plus 70 db (reference level 10^{-16} watt per sq. cm.) corresponding approximately to the sound level of the average voice at a distance of one foot, a 1000-cycle tone sounds as loud as a 50-cycle tone which is 10-db greater in intensity. And, at frequencies above 3000 cycles, greater sound intensity (or more amplification) would be required to make the higher frequencies sound as loud as those in the 300-3000 cycle range.

If all sounds were reproduced by the loudspeaker at exactly the same intensity as picked up by the transmitter, there would be nothing to worry about. For, in such circumstances, the variation in loudness would be the same when listening directly to the broadcaster. But, if the receiver volume control is adjusted for a higher or lower level than the original, the relative loudness of the various frequencies is no longer the same. Note in Fig. 1 that a sound level of 50 db at 1000 cycles—a decrease of 20 db from our originally considered level—is the equivalent of a 50-cycle sound at an intensity of about 77 db. In other words, reducing the sound intensity by about 3 db at 50 cycles causes this low-frequency note to sound as weak as a 1000-cycle note which is reduced in intensity by 20 db. At high frequencies, the reduction is substantially the same as at 1000 cycles over the range in loudness considered.

FREQUENCY COMPENSATION

It is apparent, then, if a radio is to reproduce sounds with the same relative loudness regardless of the setting of the volume control, that some means must be employed to maintain the proper balance between the various frequency components. The much-maligned tone control, which was well received by the

general public, though condemned by engineers, served in some measure to accomplish this purpose. Such devices have been greatly improved in modern receivers, and a representative example of a frequency-compensating network which automatically helps to provide better frequency balance at various volume-control settings is shown in Fig. 2. The values of the resistors and condensers which make up the filter networks connecting to the 0.5-meg and 0.25-meg taps on the volume control are so chosen that the high frequencies are attenuated more than the low frequencies and the proper balance is then approximately maintained. More elaborate circuits of this type use chokes in addition to resistors and condensers in these networks and serve to more closely approach the desired characteristic.

UNDISTORTED POWER OUTPUT

Most of us have noted that modern tubes of high power sensitivity and power output seem to provide better reproduction than the low-power types previously employed. This is particularly the case with respect to beam-power types, such as the 6L6. However, though the beam-power tubes provide high power output, the distortion at low levels is greater than with triodes. This is particularly troublesome in high-fidelity amplifiers, because the wide frequency range, and the fact that the low frequencies are often boosted in intensity, means that small degrees of harmonic distortion which would pass unnoticed in a receiver of relatively narrow frequency response result in discordant reproduction which has a bad psychological effect on the listener. The resistance-capacity filter often found in the output circuit of a beam-power tube helps to bypass some of the harmonics of these low notes and, to a much greater extent, the use of inverse feedback circuits improves reproduction by reducing distortion. But, when cost is not a limiting factor, triode amplifiers are preferred from the standpoint of low distortion and simplicity of circuit design.

One limitation of triode output stages has been the fact that the maximum undistorted output from a pair of 2A3's, for instance, is only about 12 watts in the usual form of circuit. If we want to get the requisite 20 watts or more, it is necessary to employ parallel push-pull operation, necessitating a high-priced power supply, expensive associated transformers and high voltages, because of the high grid bias required for these tubes. A new circuit, devised by Lincoln Walsh, enables an output of 35 watts to be secured from a single pair of push-pull

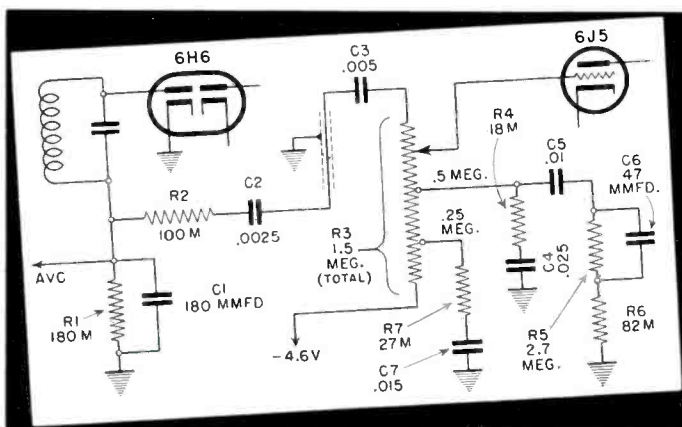

Fig. 2. The volume control in this circuit is compensated so as to provide adequate bass response at all volume levels.

operated 2A3's. The tubes are operated Class AB₂, which means that grid current is drawn over a part of the cycle. The high power output is obtained by means of a new method of biasing the grids, as shown in Fig. 3.

THE WALSH AMPLIFIER

In operation, the plate current of the output tubes returns to the filaments through R4 and the center tap of the filament winding of the power transformer. Since R4 is in the cathode circuit of one section of a 6F8G double triode, the voltage drop across this cathode resistor serves to provide the grid bias for this section of the double triode. The output plate is direct-coupled to the grid of the remaining triode section through the voltage divider R1, R2, and R3, which are so proportioned that the bias is maintained at approximately -15 volts at both input and output sections. When the plate current of the 2A3's increases, the voltage drop across R4 also increases, thus raising the grid bias and decreasing the plate current of the first section of the 6F8G. This makes the voltage drops across R1 and R2 greater, increases the positive voltage which bucks the high negative voltage at the grid of the second triode and causes the bias to become less than 15 volts negative.

The reverse process in the output circuit of the second triode section causes the junction point of R6 and R7 to become more negative, decreasing the plate current of the 2A3's and thus tending to offset the tendency of the plate current to increase. The values of R1, R2 and R3 are so chosen that, in combination with the 0.1-mfd bypass condenser, the time constant is sufficiently long to enable the plate current to effect its normal increase and decrease over a signal cycle of the lowest frequency to be reproduced, yet is not so long as to permit any permanent change in the operating point over an appreciable period. The actual time constant is of the order of 0.1 second.

In conjunction with an inverse feedback circuit, an amplifier of this type is rated to provide adequate room volume at a distortion level of about 0.1 percent. The amplifier is flat from 20 to 15,000 cycles and is used in conjunction with a compensated volume control circuit to provide up to about 35 db emphasis at low frequencies as the volume control setting is reduced.

KNOWING WHY

We have discussed in a general way those factors influencing the operation of high-fidelity receivers in order to provide

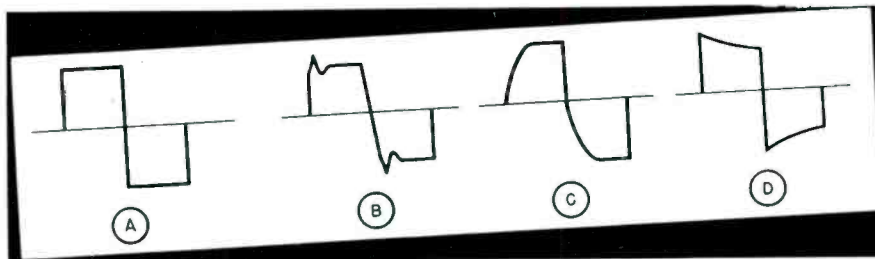

Fig. 4. Various representations of square waves in a-f testing.

a better picture of the principles underlying their design and operation. When we know why a circuit is used in a certain way, we know better how to fix it when it goes wrong. Also, when we realize that the audio amplifier response normally changes when a compensated volume control is operated at some setting other than full on, it serves to emphasize the need for checking audio-frequency response at different volume control settings to make certain that the compensating circuits are performing properly. Even more important is the fact that proper performance cannot be obtained unless replacements of defective controls are made with exact duplicates.

At the start we mentioned that installation also played a part in the proper performance of a high-fidelity receiver. Quite often we find that a short, indoor antenna provides adequate pickup to provide good reception from most local broadcast stations. This is seldom sufficient with high-fidelity receivers. The increased frequency response, particularly at the high frequency end,

causes accentuation of noise when the carrier level is below normal. Also, band-pass circuits are sometimes affected. Too much signal is much better than too little; the avc system will take care of any excess, provide a means of proper tuning, and often will resurrect a sale which might otherwise be lost. There are quite a number of models, of course, which are designed to operate with internal loops. Such receivers usually have sufficient r-f amplification ahead of the detector so that an outside aerial is unnecessary except under bad local conditions. And, in general, no external antenna will be required for f-m receivers for reception from local stations.

SQUARE-WAVE TESTING

In Section V of the Portfolio, which appeared in the September, 1940, issue, mention was made of the application of square waves to the testing of audio amplifiers. At that time, little information was available on the subject, but now there is more to report. In fact, it becomes increasingly evident that square-wave signals will come more and more into application for such testing, particularly since they reveal amplifier defects which can be uncovered in no other way.

For example, let us consider the various representations of square waves shown in Fig. 4. That of Fig. 4-A represents the normal square wave as applied to an audio amplifier. In Fig. 4-B, the effect of a transient oscillation is shown. Note that this causes a sharp wiggle at the upward and downward peaks of the wave. Of vital importance is the fact that such transient oscillations may occur at frequencies far above audibility and therefore cannot be heard. Yet they serve to overload the amplifier and thus limit its operating range. In one amplifier, a transient of this type occurred at 35,000 cycles, due to the characteristics of the output transformer used, one winding of which was employed in an inverse feedback circuit. The circuit was perfectly stable when tested with a sine-wave audio oscillator over the normal audio range extending up to (Turn to page 31)

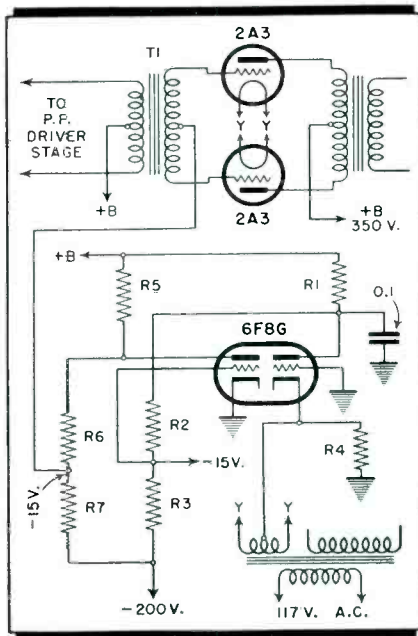
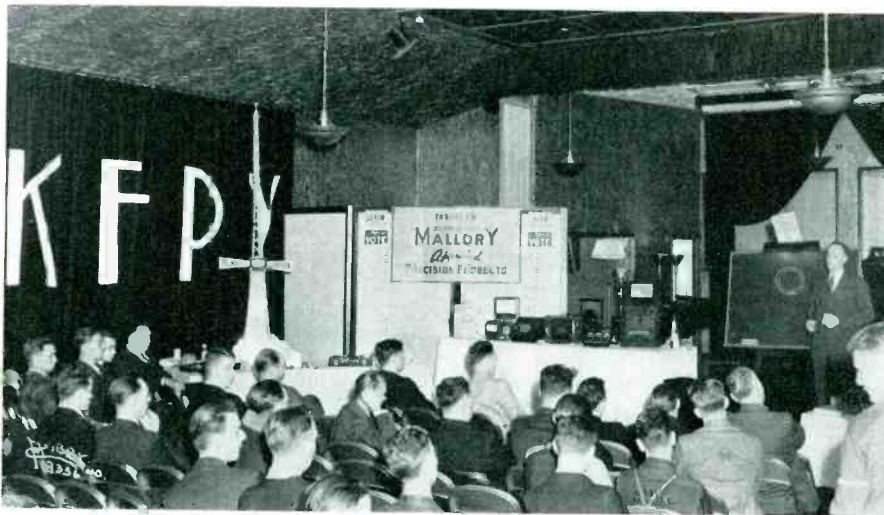

Fig. 3. This Class AB₂ amplifier has a roving bias that adjusts itself to the signal level. Explanation in text.



BILL COON MEETING AT KFPY STUDIO, SPOKANE, WASHINGTON

SET-RECONDITIONING DRIVE

IN the days when Mohammed did his best to inveigle the mountain to come to him, and then sagely recorded the best method of procedure, radio and its selling and service problems were of no moment.

Taking that leaf out of Mohammed's notebook, the Spokane Radio Company, Inc., distributors, in Spokane, Washington, recently applied the prophet's logic with remarkable results—bringing up the time-worn advertising bromide; You, too, can learn to . . . etc.

Radio's selling and service problems in the West are distinctly different from those of the thickly populated centers. For years, Spokane Radio has done everything possible to follow the pro-

cedures successfully used in the East in aiding radio servicemen to a better understanding of successful practices in selling their services and merchandise.

Every effort of its kind, although beneficial, had to be acknowledged as being far short of the possible success it could be. The smaller markets and the great distances of the West were combined in an alliance that could not be overcome in trying to bring into a central point, dealers and servicemen from the Northwest. The ever-widening scope of radio service technique has placed ever-increasing demands upon the time of the serviceman, leaving few off moments in which to keep up with the march of progress in the technical and

merchandising phases of his work.

The specific problem dealt with in this case was the matter of servicemen doing a *complete reconditioning job* on radio receivers rather than the partial "tube testing" the uninformed owner usually requests.

To start with, William Coon, of Portland, Oregon, who is dean of western servicemen, was retained by Spokane Radio Company for a two-week period to go on tour throughout northwestern centers. Starting October 7th, Coon appeared at a meeting in Yakima, Washington. Then, in daily succession, he hit meetings in Walla Walla, Pullman, and Spokane, Missoula, Kalispell, Great Falls, Helena, Butte, Bozeman, and Billings were Montana cities visited in that order. Pocatello, Twin Falls, and Boise, Idaho meetings preceded the closing session on October 24th in La Grande, Oregon.

As soon as arrangements were concluded, late in August, the Spokane Radio Company house organ "SRC Service News" went to work beating the drums for the forthcoming meetings. Mr. Coon, his message, who would be interested, a schedule, and other phases of the "junket" were given feature-story handling. The usual "ports of call" for servicemen in all localities were liberally posterred with announcements of the project. Post cards were utilized a day or two in advance to herald the imminence of Mr. Coon's appearance. In every community the response was gratifying. An average of better than 90 per cent of all servicemen in all communities were present at the meetings.

Meetings which were held in the
(Turn to page 30)



Bill Coon addressing servicemen congregated in a hotel, at Great Falls, Montana, during the set-reconditioning drive sponsored by the Spokane Radio Company.

Serviceman's Diary

By J. P. HOLLISTER

WEDNESDAY—You know how it is—sometimes you sit at the wheel, grinning to yourself about something which just happened to pop into your mind; maybe something which never happened. And, all of a sudden, you find that you have been grinning right at someone you don't know and maybe never saw before. You wipe the silly grin off fast, but you feel like a fool just the same.

It was that way this morning. I was waiting at the corner for the green light, dreaming about Jeanie With The Light Brown Hair, when I suddenly realized I was smiling into a pair of merry blue eyes which were regarding me with some amusement. A round, light brown fur hat topped the head of the possessor of the amused orbs, and a jaunty, short coat and high-heeled boots

trimmed with the same fur made her look, at first, like a dolled-up little girl rather than a woman in her twenties.

She kept right on looking at me and somehow I forgot to stop grinning. I thought for a moment that she must be some customer whose set I had fixed in the Summer. (You never recognize them when they are dressed up, if you have only seen them once or twice, and then only in house dresses.) So, playing safe, I asked her how the set was working.

"Fine," she replied. "But if something ever happens to it, I'll get in touch with you. Are you driving toward Main Street?"

"Sure, sure," I told her. "If you want a lift, just hop in and I'll drop you off wherever you say." So she wasn't a customer at all.

"That's lovely of you." She hustled in, noticing that the traffic light had changed, and turned, partly facing me in the seat. I've been standing here for five minutes, waiting for a street car, and there hasn't been one in sight. I just couldn't get my car started this morning, and I simply must—"

"Don't worry," I told her. "I'll get you to any place you want to go in no time. That is, if I don't get pinched."

"Arrested?" she said. "Why ever would . . . ?"

"Don't you know," I cut in, "that there's a law against taking hitch-hikers on a commercial vehicle? It's really a serious offense."

She didn't know that I was kidding her.

"Well," she said, "if you're breaking a law, you'd better let me out. I wouldn't want to be the cause of any trouble."

I opened my mouth to tell her to forget it when I suddenly heard the piercing siren of a police car. I glanced at the rear view mirror and saw a green and white Plymouth speeding toward me. I slowed down as the cops pulled alongside. One waved me over to the curb. Then they stopped in front. I hopped out, telling the girl to wait.

"What's the matter, Mac?" I asked.

"The receiver's shot," the cop answered. "It was all right when we left the station but it kicked out just after we turned the corner. Maybe you can check her here and save us a trip back for a spare set."

I gave it a none-too-gentle massage with the butt of my hand. At the third wallop, the set kicked in again. Apparently either a loose connection or a bad tube. So I told Mac they'd better run back to the station and I'd follow along and make the change.

Sometimes I'm sorry Jerry ever took over the contract to service the police radio system, but it has helped out during the dull season. They really need about ten new receivers, but the Chief of Police, who is also a big shot on the Village Board, just won't ask for an appropriation. We could make a nice piece of change on the sale if he would.

I climbed mournfully back into the truck.

"I've got to go to the Police Station," I told her. I thought she'd be scared, but she wasn't.

"How terribly exciting," she murmured. "I'm sorry if I've made trouble, but I'll go along with you and see if I can't clear up things." She looked out

(Turn to page 29)

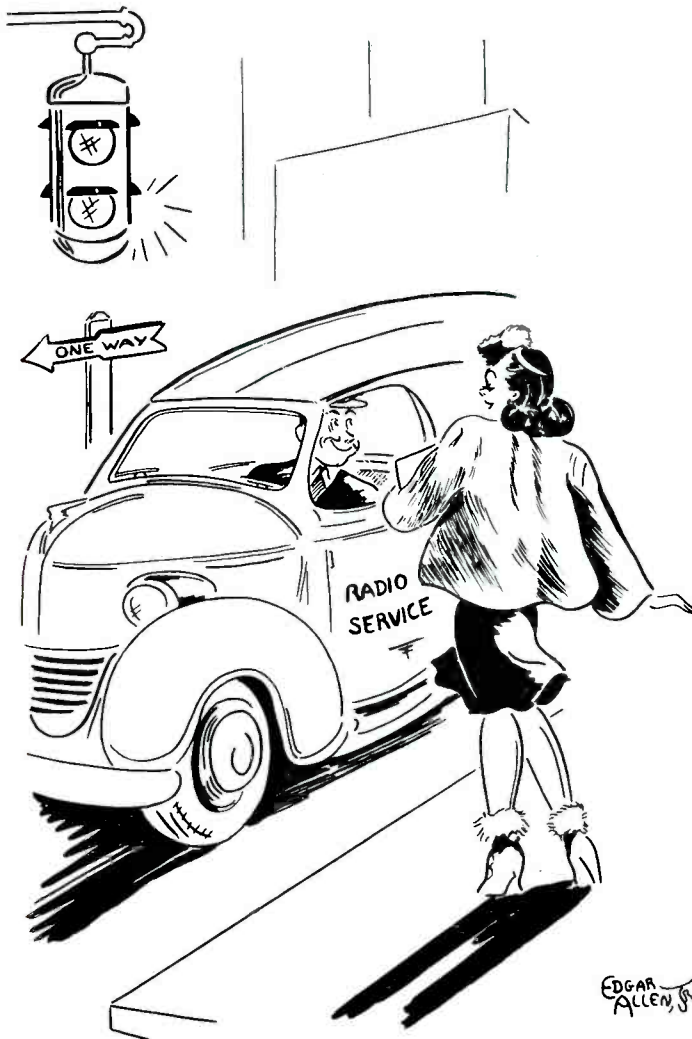

I suddenly realized I was smiling into a pair of merry blue eyes which were regarding me with some amusement.

Circuit Court

I-F "CONTACT" BIAS

CONTACT-POTENTIAL biasing of a-f voltage-amplifier tubes has become accepted practice—the biasing voltage being developed across a grid resistor of exceptionally high value. In the *Motorola Model 40-40B* battery-operated receiver, this method of obtaining initial bias is also applied to the 1N5GT i-f amplifier tube.

As shown in Fig. 1, the secondary of the i-f transformer is grounded through the resistor *R* which has a value of 8.2 megs. In order to prevent a build-up of r-f voltage, it is bypassed by the .01 paper condenser *C*.

The small amount of grid current normally flowing in the tube passes through this resistor, causing a voltage drop which is negative with respect to the grid. This voltage constitutes the initial bias.

In the circuit shown the i-f tube receives no avc voltage, this being applied to the modulator tube only. If the signal tuned in is of sufficient amplitude to over-ride the initial bias of the i-f tube, there will be a momentary increase in grid current through *R* and a consequent increase in the value of the bias voltage. At the same time an avc voltage is developed in the diode load circuit which automatically reduces the gain of the modulator tube; hence, the entire signal-frequency circuit is self-balancing and a satisfactory bias is maintained on the grid of the i-f tube under all conditions.

KILLED OSCILLATOR

VARIOUS MEANS are employed in phonoradio combinations to keep radio signals

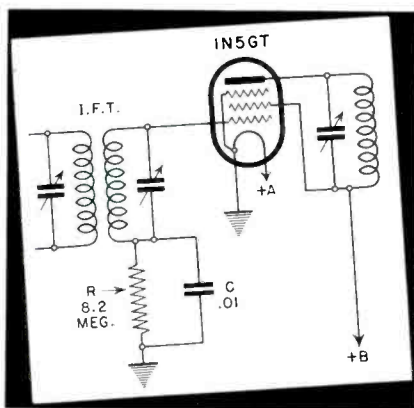

Fig. 1. Bias for this i-f tube is developed across the 8.2-meg. resistor *R*.

from riding through the audio system when the phonograph is in use. In the *Emerson Model FA-408*, this is accomplished by killing the oscillator.

As shown in Fig. 2, the dpdt switch *S* controls the operations. The left-hand section of the switch performs the usual role of connecting the high side of the volume control either to the diode detector or the crystal pickup. The right-hand section buttons the oscillator coil *L* to ground when the radio is in use, and puts the oscillator out of commission by unbuttoning coil *L* from ground when the phonograph is in use. In the latter position of the switch, with no oscillator

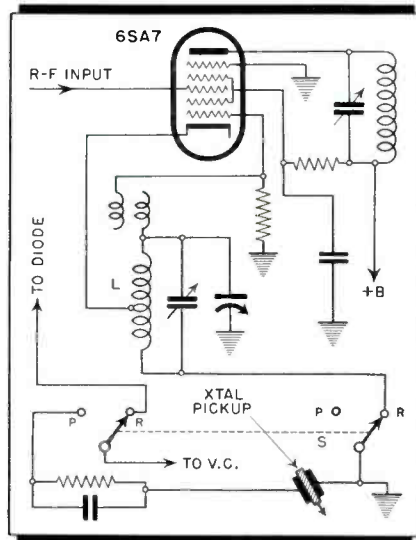

Fig. 2. The oscillator is killed for phono operation by ungrounding the oscillator coil.

voltage present, incoming signals are not converted to the i-f frequency. Hence, the i-f amplifier is receptive only to signals with a fundamental frequency at or near its peak of 455 kc. But, this receiver employs a 455-kc trap in the cathode circuit of the r-f tube (see page 23, January RSD) with the result that no signal of any nature reaches the diode detector.

HI-LO AC-DC

BY THE SIMPLEST of changes, the new *Ward Airline Model 04BR-397A* receiver may be operated from either a 105 to 125-volt, 50 to 60-cycle or d-c line, or from a 210 to 250-volt, 50 to 60-cycle or d-c line. The change is accomplished by reversing the position of the ballast tube in its socket.

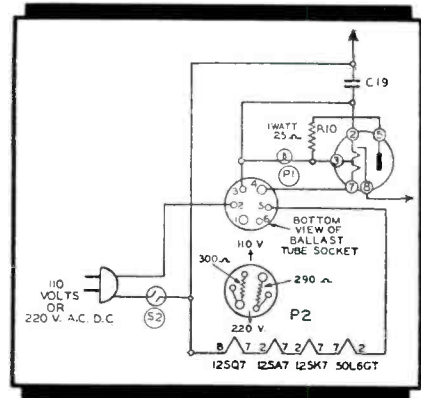

Fig. 3. Changing the position of the ballast tube in its socket equips the set for 220-volt operation.

The portion of the circuit involved is shown in Fig. 3. The ballast tube, *P2*, fits the socket shown directly above it. It is positioned in the diagram, with respect to the socket, for 220-volt line operation. Inserted in this position, the 300-ohm ballast-tube resistor is placed in series with the line and the 35Z5GT rectifier, and the 290-ohm resistor in series with the tube heater string.

Reversing the position of the ballast tube in its socket, so that the lower pin is placed in socket hole 4 instead of 1, ties together the socket terminals 2 and 3 and 4 and 5 for 110-volt operation, the ballast resistors then being out of circuit.

DIODE-BIASED A.F.

AN INTERESTING example of diode biasing in an a-f amplifier is incorporated in the new *Western Auto Supply Co. Truetone Models D1090 and D1091* auto-radio receivers. The portion of the schematic involved is shown in Fig. 4.

The circuit is conventional with the exception of the grid return of the 6SK7 a-f tube. Instead of connecting directly to ground, the 6-meg grid resistor *R1* is connected to the point between the filter resistor *R* and the blocking condenser *C*, then grounded through the 300,000-ohm resistor *R2*.

Under no-signal conditions, the 6SK7 receives an initial bias resulting from the voltage drop across *R1* and *R2* in series (contact potential). When a signal is tuned in, the negative voltage developed in the diode load circuit *R-R2* is applied not only to the avc bus but also to the 6SK7 grid. The voltage applied to the avc bus is the total drop across

Circuit Court

R and *R*₂; the voltage applied to the 6SK7 grid is the drop across *R*₂ only. Since the volume control *R*₃ is isolated from the d-c voltage in the diode circuit by condenser *C* and further isolated from the 6SK7 grid by condenser *C*₁, the signal-induced bias on the grid remains constant (for a given signal voltage) irrespective of the position of the volume-control arm.

CLASS B FEEDBACK

IN THE NEW auto-radio *Truetone Models D1091* and *D1191* by *Western Auto Supply*, a two-stage inverse feedback loop

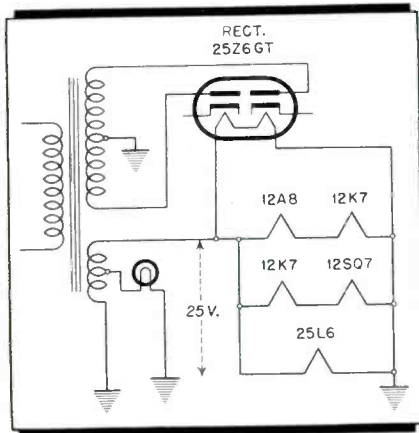

Fig. 6. Tubes in midget are connected in series-parallel and operated from power transformer.

is used in conjunction with the Class B audio amplifier.

The portion of the circuit involved is shown in Fig. 5. A 6K6 drives a 6N7 Class B tube through the transformer *T*. The output transformer *T*₁ has two secondary windings, one to supply the speaker and the other for supplying the feedback voltage.

Feedback is to the cathode of the 6K6 driver. This is accomplished by placing the additional output transformer secondary in series with the 6K6 cathode

Fig. 5. Separate winding on output transformer is used for feedback in Class B stage.

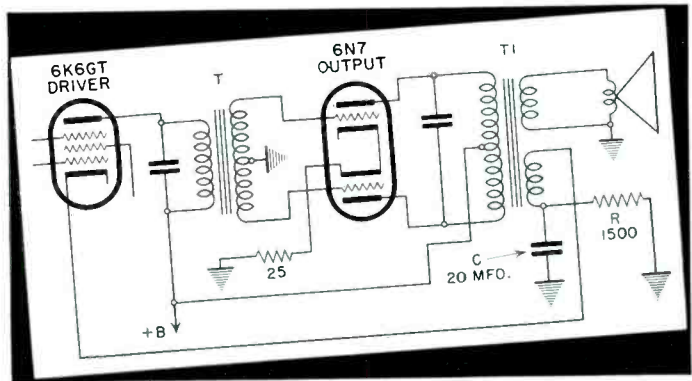

and the cathode-bias resistor *R*. Since resistor *R* is bypassed by the 20-mike condenser *C*, the feedback voltage developed in the cathode circuit is only that appearing across the output transformer feedback winding.

GANGED HEATERS

IN THEIR NEW *Model 7327 Silvertone, Sears, Roebuck* have provided transformer operation and full-wave rectification in what is otherwise a receiver of typical ac-dc design. Hence, from the engineering viewpoint, the design of the set involved nothing more complex than a conversion of the power-supply system.

An abbreviated version of the circuit is shown in Fig. 6. The power transformer has a one-to-one ratio between primary and rectifier secondary so that the plate and screen voltages will not exceed the safe values for the tubes and components employed. The heater winding is tapped at 6 volts for the pilot light, the total potential being 25 volts.

The receiver uses two 25-volt tubes and four 12-volt tubes, as indicated in the diagram. The heaters of the 12-volt tubes are connected in series in pairs, which pairs are then connected across the 25-volt heater winding of the power transformer.

Should one of the 12-volt tubes burn out, it is easily located, since the full 25 volts will appear across the heater connections of the tube in question.

SILENCING BIAS

A RADIO signal silencer with a Scotch accent is used in *Ward's Airline Model 04WG-1108A* for putting the gag on programs when the phonograph is in use. The essential portions of the circuit are shown in Fig. 7.

In the radio position, switch *S*—only a portion of which is shown—serves no active purpose. In the phonograph position, however, it connects the avc line to the center tap of the power trans-

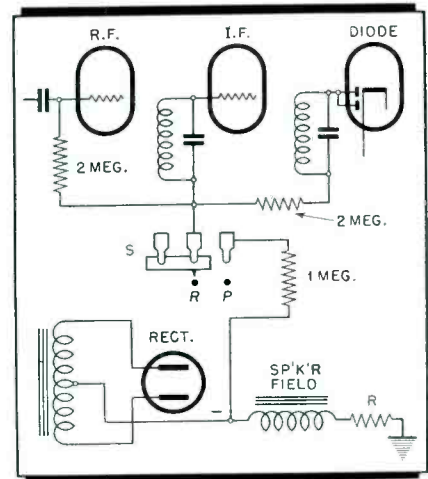

Fig. 7. The r-f tubes are over-biased in this circuit when the phonograph is in use.

former through a 1-meg resistor. This point is considerably negative with respect to ground by virtue of the voltage drop across the speaker field and resistor *R*. Hence, this comparatively high negative voltage is introduced into the avc line and the signal-frequency tubes are heavily biased. Result—practically no gain.

The Scotch accent rests in the fact that the s-f tubes draw only a wee amount of plate and screen current during phonograph operation, which saving not only helps to defray the expense of running the phono motor but should soothe the soul of the economy-minded individual.

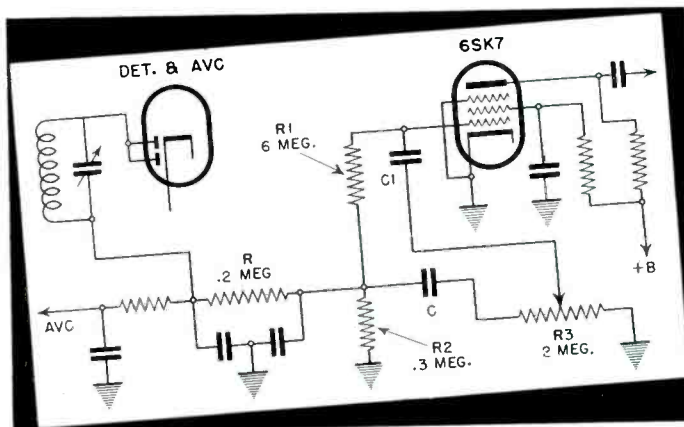

Fig. 4. The 6SK7 a-f tube in this circuit is diode-biased by returning the grid to a point in the diode load circuit.

Presenting—

NEW PRODUCTS

RCA

Re-Entrant Speakers—Two new metal re-entrant trumpets, and three new speaker mechanisms providing a variety of power for large areas where good directional characteristics are desirable.

Type MI-6303 is a 5½-foot baffle folded back to a length of 31 inches. Bell diameter is 28½"; frequency response 150 to 7000.

Type MI-6302 is a 3½-foot baffle compressed into 19". Bell diameter is 21½"; frequency response 200 to 7000.

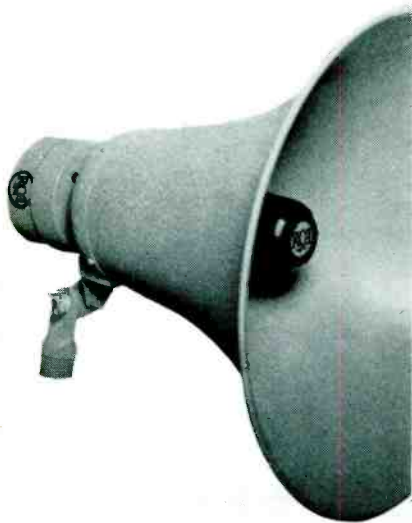

The three loudspeaker assemblies, providing 15-, 12- and 10-watt power, are interchangeable with both horns. By commercial Sound Division, RCA Manufacturing Co., Inc., Camden, N. J. RADIO SERVICE-DEALER.

PRECISION APPARATUS

A-C Ammeter—Series J multi-range a-c ammeter can be used on line frequencies from 25 to 60 cycles; 300 ma full scale to 60 amperes; 8 a-c ranges; special red correction scale for direct reading on 25-cycle service; 45/8" square type meter. Meter accuracy 2 percent. Available in three models. When used with either the Precision Series 844, 854 or 862 multi-range testers, it provides a complete all-purpose

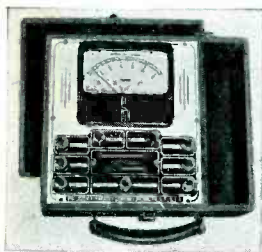

ac-dc industrial type circuit analyzer. By Precision Apparatus Co., 647 Kent Ave., Brooklyn, N. Y. RADIO SERVICE-DEALER.

SICKLES

"Check-A-Loop"—An efficient service instrument for checking loop antenna alignment. By its ability to raise or lower the

New! Sickles
LOOP CHECKER

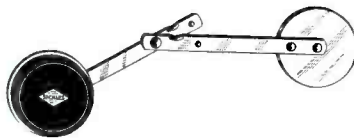

inductance of a loop, it quickly shows whether trimming capacity should be increased or decreased. Has a metallic disc at one end and a special high permeability material on the other. Both the disc and the bakelite container are mounted on a folding bar. When not in use, the unit can be folded and stowed away in the service kit. Provides quick work for the serviceman. By The F. W. Sickles Co., 165 Front St., Chicopee, Mass. RADIO SERVICE-DEALER.

HOWARD

Recording Discs—Constructed from a soft steel base, coated with special lacquer known as Type C which eliminates tearing, permitting the stylus to cut clean, even grooves. Discs are hardness processed for longer life and better reproduction of the higher frequencies. The coating is of even thickness and not in layers. Available in



6½", 8" and 10" sizes. By Howard Radio Co., 1731 Belmont Ave., Chicago. RADIO SERVICE-DEALER.

TURNER

Magnetic Pickup—Model MM high-impedance magnetic unit with built-in volume control, designed for use with stringed musical instruments. Special clamp permits fastening to instrument without the use of tools or adhesives. Finished in brown enamel and measures 3⅜" long by 1 5/16" wide. Complete with 25-foot cable. By The Turner Co., Cedar Rapids, Iowa. RADIO SERVICE-DEALER.

WILCOX-GAY

Red Label Disc—New Recordio quality recording blanks with metal bases and coating of slow-burning material, in 6½", 8" and 10" sizes, marketed in convenient packaging album which is used by the consumer for record storage. Space on album cover for listing the nature of each recording contained in the 12-pockets provided. By Wilcox-Gay Corp., Charlotte, Mich. RADIO SERVICE-DEALER.

HALLICRAFTERS

FM-AM Tuner—Model S-31 has an undistorted output of 130 milliwatts, making it adaptable to any high-fidelity audio equipment. The two tuning ranges are 540 to 1650 kc and 40 to 51 mc. Terminals are provided for standard and doubler an-



tennas. Outputs of 500 and 5000 ohms are provided, plus a headphone jack for monitoring purposes. The panel is the standard rack-mounting type, suitable for rack or cabinet mounting.

The f-m channel employs 1852 and 1853 tubes in its two 4.3-mc stages, 6SJ7 limiter and a 6H6 discriminator. The 455-kc a-m channel includes a single 6SK7 with special band-pass input circuit, and a 6SR7 which serves as detector and avc, and its triode section as the output stage for both a-m and f-m channels. A 6SK7 t-r-f stage and a 6SA7 converter provide the r-f input to both channels. By Hallicrafters, Inc., Chicago. RADIO SERVICE-DEALER.

SHURE

Dynamic Mike—Series 508 "Stratoliner" Dynamic Microphone with wide frequency response. Unaffected by heat or humidity. Built-in transformer. Swivel head for semi-directional or non-directional operation. Built-in cable connector. Standard 5/8"-27 thread for stand mounting. Avail-

(Turn to page 24)

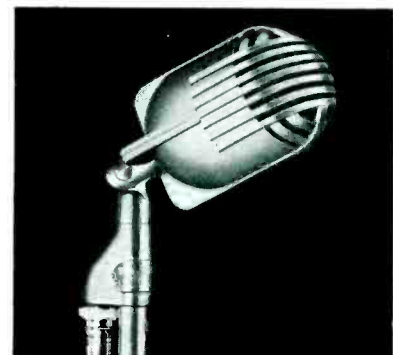

Shop Notes

RCA O-2, O-6

Motor Adjustments

Speed variations or wows may be experienced with these instruments due to a variety of causes. Some of the troubles and corrections are listed below:

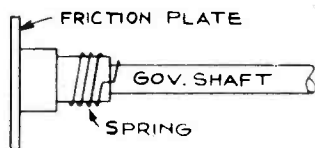

1. A regular wow occurring on every revolution of the turntable, or every few revolutions.

(a) A frequent cause of this difficulty is faulty adjustment of the governor springs. If the governor weights seem to oscillate in and out when the motor is in operation, the spring tension of the three weights may not be evenly balanced. Loosen the three spring clamping screws and position the springs so that all three weights are held with the same tension.

(b) Another possible cause of this trouble is faulty adjustment of the governor bearings. To adjust these bearings:

First: Set the speed regulator lever so that the face of the felt friction pad is accurately parallel to the governor friction plate.

Second: Loosen both governor bearing set screws and position the governor so that the motor revolves at rated speed (78.4 rpm).

Third: Adjust the mesh of the worm and the fiber drive gear by turning the eccentric bearings. These should be set so that the worm meshes properly with the fiber gear without binding.

Fourth: Adjust the distance between bearings so that the governor turns freely with a minimum of end-play.

(c) A take-up spring is mounted on the governor friction plate shaft to ensure against lost motion and erratic operation of this plate. It is essential that this spring be in place and adjusted to provide adequate tension. It should be positioned as indicated in the sketch.

(d) Marred or broken teeth on either gear on the turntable shaft or on the intermediate gear shaft may cause this trouble. If inspection shows this to be the case, the defective gear should be replaced.

2. The turntable loses speed or wows on the louder parts of a record:

(a) This may be caused by failure of the governor to respond accurately to speed changes, due to excessive or irregular friction between the sliding friction plate and the governor shaft. When this occurs it may be corrected by removing the weights and working the plate back and forth until it frees up. If the governor shaft does not have a smooth surface it may be necessary to smooth it down slightly using "Crocus Cloth" or to replace the governor.

(b) This condition may also be caused by excessive friction in any part of the motor. Be sure that the governor bearings are properly adjusted as described in section 1 (b). Lubricate all bearings in the motor using a high grade light oil such as RCA Stock No. 7227 Spring Motor Oil. The governor shaft, friction plate, and felt friction pad should also be lubricated with this oil. Lubricate the worm with a light grease such as RCA Stock No. 10975 Electric Motor Grease. Remove the main spring and pack it with a graphite lubricant such as RCA Stock No. 7228.

3. The turntable speed changes erratically over long periods of time.

(a) This may be caused by binding of the main spring due to improper lubrication. To correct this pack the spring with graphite grease as described in section 2 (b).

(b) Make sure that the top of the main spring housing does not rub on the end of the winding shaft.

(c) Inspect the gear teeth on the main spring gear. If these are marred or broken, it may be necessary to replace the spring assembly.

RCA TYPE 1629 TUBE

The 1629 is a high-vacuum, heater-cathode type of electron-ray tube designed to indicate visually, by means of a fluorescent target, the effects of a change in the controlling voltage. With the exception of

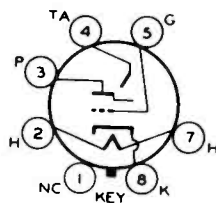

the heater rating of 12.6 volts and 0.15 ampere, the electrical characteristics are the same as those of the type 6E5 electron-ray tube.

The socket connections for the 1629 electron-ray tube are shown in the accompanying sketch.

SILVERTONE MODEL 7327

Alignment Precaution

It should be noted that on this set the dial is not fastened to the gang condenser or any of its supporting members, and since the condenser is flexibly mounted there can be motion of the condenser shaft with respect to the dial scale. This construction has been adopted to make the set as free from microphonic howling as possible.

The first step in aligning the set is to remove the pointer, by pulling it off of the condenser shaft and inspecting the shaft to see that it is approximately in the center of the hole in the dial scale. If this is not the case, the screws holding the dial should be loosened and the scale

moved until the gang condenser shaft is centered in the hole. Replace the pointer, close the gang condenser and slide the pointer until it coincides with the horizontal line dividing the two scales, kilocycles and meters.

SILVERTONE MODEL 7325 EXPORT

Band-Spread Alignment

The most satisfactory method of aligning or checking the spread-band ranges is on actual reception of short-wave stations of known frequency, by adjusting the magnetite-core oscillator coil for each band so that these stations come in at the correct points on the dial.

In exceptional cases, when the set is being serviced in a location where the noise level is so high as to prevent reception of short-wave stations, a test oscillator may be used for alignment, but an extremely high degree of accuracy is required in the frequency settings of the test oscillator, as a slight error will produce considerable inaccuracy on the spread-band dials. The frequency settings of the test oscillator may be checked by one or both of the following methods:

1) Determine the exact dial settings of the test oscillator (for frequencies at or close to the specified alignment frequencies) by zero-heating the test oscillator against short-wave stations of known frequency.

2) Use harmonics of the standard broadcast range of a test oscillator, or by zero-beating against standard broadcast station frequencies.

When a test oscillator is employed for spread-band alignment, a final check should be made on actual reception of short-wave stations of known frequency, and the magnetite-core oscillator coil for each band should be re-adjusted so that the stations come in at the correct points on the dial.

WELLS-GARDNER SERIES 6A43-1, 6A43-3

Possible Hum

In a few cases in the first shipments of these chassis, some of the speakers had reversed green lead and brown lead connections at the speaker plug. If hum is encountered, check these connections.

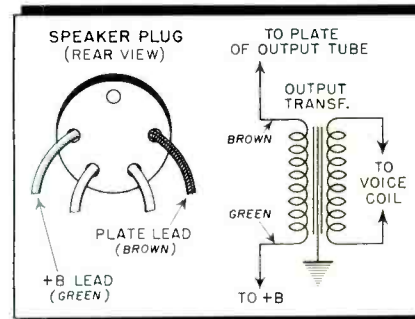

The accompanying sketch shows the correct connections for the green (B+) and brown (plate) speaker leads.

(Turn to page 35)

(Continued from page 22)

able in 35-50 ohms, 200-250 ohms, and high-impedance models. Permissible cable length practically unlimited with low-impedance models. High-impedance models may be used with crystal mike amplifier and other amplifiers with input impedance of 100,000 ohms or more. By Shure Brothers, 225 W. Huron St., Chicago, Ill. RADIO SERVICE-DEALER.

UTC

"Steady-Volt"—A voltage regulator for maintaining constant voltage for laboratory apparatus, electronic instruments, etc. Input voltage may vary from 95 to 130 volts.



The output voltage is maintained within one percent accuracy. Negligible variation in output voltage from no load to full load. A triple output receptacle is provided, affording 110, 115 or 120 volts output. No moving parts. Based on a magnetic principle which assures instantaneous response. By United Transformer Corp., 150 Varick St., New York, N. Y. RADIO SERVICE-DEALER.

HOWARD

Record Needles—New low-cost recording needle which will cut more than two hundred 6½" records. A permo metal tip of extreme hardness is employed.



Also two new long-life playback needles, one especially designed for commercial records and the other a new playback needle for home recordings. By Howard Radio Co., 1731 Belmont Ave., Chicago. RADIO SERVICE-DEALER.

ERWOOD

Portable P. A.—An 8-watt p-a system particularly adapted to smaller assemblies encountered in some churches, schools, clubs, etc. The complete system includes a 10" p-m speaker, one desk type crystal microphone and a 5-tube amplifier with an output of 8 watts. Portable carrying case measures 14" wide, 11" deep and 12½" high. Weighs less than 28 pounds. Case

has tweed finish. By Erwood Sound Equipment Co., 223 W. Erie St., Chicago. RADIO SERVICE-DEALER.

NEW LITERATURE

C-D Capacitors—The 1941 Abridged Catalog No. 185A, covering the line of C-D mica, paper, Dykanol, and wet and dry electrolytic capacitors, has just been issued by the Cornell-Dubilier Electric Corp., South Plainfield, N. J.

G.E. V-L Indicators—General Electric Co., Schenectady, N. Y., has issued Bulletin GEA-3145A on their new Type DO-61 VU Volume-Level Indicators for broadcasting, sound recording and communication systems.

G.E. Square-Wave Generator—This new instrument, for instantaneous testing of audio amplifiers, etc., is fully described in Bulletin GEA-3442, a copy of which may be had on request to the General Electric Co., Schenectady, N. Y.

J.F.D. Wall Racks—J. F. D. Mfg. Co., 4111 Ft. Hamilton Parkway, Brooklyn, N. Y., has issued a 4-page bulletin on their new Cable and Cord Wall Racks for jobbers and servicemen. Copy on request to manufacturer.

R.I.S. Catalog—Radio Inspection Service Co., 227 Asylum St., Hartford, Conn., has released their latest 300-page catalog to the trade. Copy on request.

Amplifier Catalog—An interesting 8-page catalog of self-balancing, drift-correcting direct-coupled amplifiers is now available from the Amplifier Company of America, 17 W. 20th St., New York, N. Y.

Cinaudagraph Speakers—An 8-page catalog describing the complete line of Cinaudagraph speakers, including the new woofer-tweeter units, has been made available by Cinaudagraph Speakers, Inc., 2 Selleck St., Stamford, Conn.

RCA Tube Chart—The new 16-page RCA Receiving Tube Characteristics Chart is now off the press. It covers 309 types of receiving tubes, retains the convenient booklet form of the preceding edition, and includes a classification of tube types according to their cathode voltages and functions. The last two pages show socket connections with RMA designations.

A copy may be had on request to Commercial Engineering Section, RCA Manufacturing Co., Inc., Harrison, N. J. Ask for Chart 1275-B.

Rissi Catalog—With the opening of a new, larger store at 1112 West Warren Ave., Detroit, Mich., Rissi Brothers announce the publication of a 200-page net price catalog with handy index.

Will be sent free to anyone requesting a copy on their letterhead.

NEWS

Howard-Cert—Howard Radio Co., Chicago, has appointed Art Cerf to take over

their communication receiver line in upstate New York.

Universal—Universal Microphone Co., Inglewood, Cal., has discontinued its line of recording machines with the single exception of the professional model. It will also continue to produce the recording chassis job for other manufacturers and for jobbers.

R.C.P. Appointments—Radio City Products Co., New York, has appointed Ralph Gregory as sales representative for the States of Mississippi and Tennessee.

Richard A. Hyde takes over the Mountain States area, including Utah, Colorado, New Mexico and Arizona.

Neely Expands—Norman B. Neely, West Coast manufacturers agent, recently opened an office at 420 Market St., San Francisco, Cal. Homer E. Beren, sales engineer, will be in charge of the San Francisco office, spending his full time in the Northern California territory.

Alliance Package—Alliance Manufacturing Co., Alliance, Ohio, are now packing their complete line of Even-Speed phono-motors in individual cartons for the radio serv-



ice trade. They have many convenience features, such as easier handling, easier storing and as a display in the jobber's showroom.

Worner Display—Worner Products Corp., Chicago, have released a new counter display featuring a demonstration model of the new Worner Photoelectric Announcer. It is made of metal and presents a striking appearance.

RCA Service News—The first edition of the "RCA Radio Service News" to be prepared by its new editor, M. M. Brisbin, is being mailed to thousands of radio service dealers. Several innovations are incorporated in the publication in its new form.

RCA Mail Service—After an extensive survey of radio servicemen's practices revealed that several new RCA service test instruments have opened up a wider range of possibilities in the radio electronic and communication service fields than had been known to exist, RCA has arranged to keep servicemen informed of latest developments in new applications of the test instruments. The service will be free to all registered owners of RCA test instruments.

PHONO PICKUPS

(From page 7)

cycles with pickups equalized for 300 and 800 cycles respectively. The flat curve *A* is that of the pickup properly equalized; the curve *B* that of the pickup equalized for a 300-cycle turnover. It will be seen that curve *B* rises rapidly from 300 cycles at zero db to approximately 8 db at 800 cycles.

ADJUSTMENTS

The ordinary bass and treble tone controls are usually satisfactory for making proper compensation and, being variable, have the advantage that the overall characteristics of the reproducing equipment can be varied at will for each different make of record. Best positions of the controls should be determined by ear. The listener can adjust the controls to suit himself and mark the control positions on the record envelopes or albums for future reference.

If such controls are not available, they may be easily installed, or the pickup circuit can be compensated to meet individual requirements—again judging by ear. On the whole, a pickup equalized for a turnover frequency of 500 cycles makes a good compromise, in which case no variable adjustments are required. If this procedure is to be followed, the equalization values provided by the pickup manufacturer should be used.

It must be considered, however, that, unless measured, the frequency characteristic of the amplifier and speaker with which the pickup is to be used is an unknown quantity. Unless inverse feedback is employed, the chances are that the amplifier curve will not be flat. Therefore the pickup response should be modified to "fit" the amplifier characteristics.

The procedure is not at all complex if the ear is made the final judge, as it should be. Bass and treble frequencies can be raised or lowered at will right in the pickup circuit.

The magnetic pickups referred to in this article are internally compensated and have sufficient bass response for all purposes. Treble can be reduced by means of the usual tone control.

Circuits for altering the response of crystal pickups are shown in Fig. 4. If more bass is required, the low-frequency end of the response curve can be raised by increasing the value of the volume control *R2*, as shown at *A*. To obtain the desirable flat response, a series equalizer may be added, as shown at *B*. The values for *C* and *R1* comprising the equalizer can be varied over wide limits. Increasing the value of *R1* decreases output. Increasing the value of *C* increases the high-frequency response.

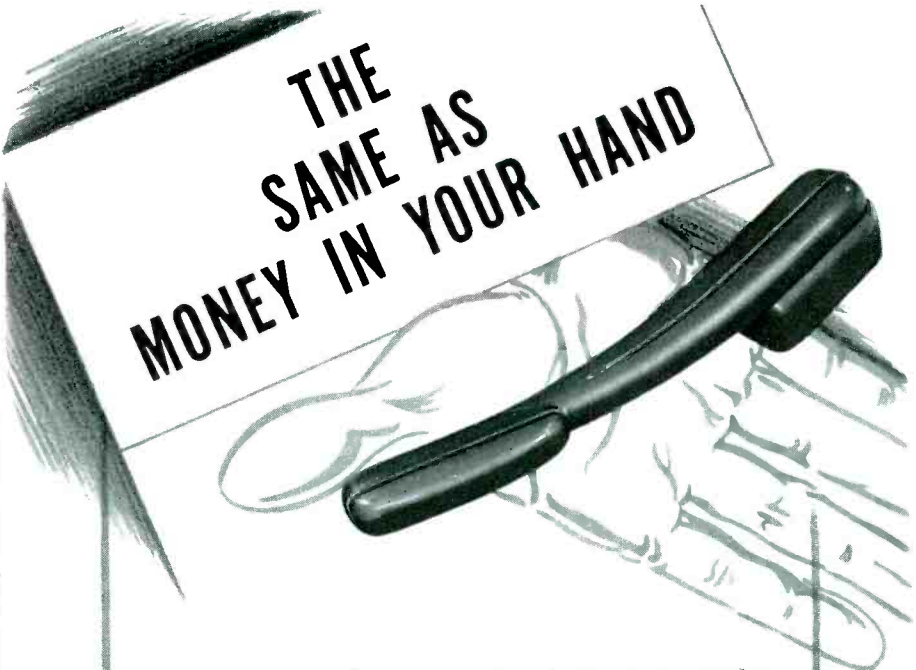

THE SAME AS
MONEY IN YOUR HAND

● Yes, sir, Mr. Radio Parts Dealer and Mr. Service Man, here is a comer! It can't miss! Astatic's Low Pressure Crystal Pickup with built-in, permanent sapphire stylus has so many advantages over conventional models that every new installation or replacement can be a low pressure pickup with "low pressure" selling. Here is a pickup that eliminates practically all wear on records, dispenses with the necessity for changing needles and improves reproduction by reducing surface noise and distortion.

Made in two models, FP-18 and FP-38, Astatic Low Pressure Crystal Pickups have a stylus pressure on the record of only one ounce, scarcely more than one-third the conventional weight. Under this low pressure, records will retain their newness for years. Permanent sapphire styli, incorporated in these Pickups, does away entirely with the necessity for changing needles. Reproduction is noticeably improved.

Astatic Low Pressure Crystal Pickups are being nationally advertised and sold and are being used by many leading set manufacturers in new models. Make every replacement sale an Astatic Low Pressure Crystal Pickup and your customers will be more than pleased. All Pickups are specially wired for quick and easy installation.

Literature is available

In Canada: Canadian
Astatic, Ltd., Toronto,
Ont.

Astatic Crystal Products
Licensed Under Brush
Development Co. Patents

ASTATIC

ASTATIC MICROPHONE LABORATORY, Inc.
YOUNGSTOWN, OHIO

NEW! *And Now* more than ever UNBEATABLE

—And Just as Easy to Own!

More than 3000 SUPREME Model 504 Tube & Set Testers in constant and profitable service have proven it to be an unbeatable value in the test equipment field. NOW SUPREME presents Model 504-A, which offers even more PLUS features, including miniature tube sockets, noise tests and battery tests.

These EXTRA features plus all the functions originally found in the Model 504, make the 504-A your logical choice in a combination tube and set tester.

SPEED—As a multimeter, 31 ranges of five functions are at your finger tips. 29 of these ranges are available through two pin jacks and two rows of quick acting push buttons. Functional switches are on one side of the panel and range switches on the other.

As a tube tester, merely rotate the smooth operating roller chart to the type tube desired and "follow the arrows." Leakage tests are equally easy and fast. Simple connections for noise tests.

As a battery tester, connect battery to plainly marked pin jacks after setting range for battery to be tested—1.5—3.0, etc. Read condition of battery on "GOOD-REPLACE" scale. Proper load automatically applied.

Speed is also maintained in checking electrolytic capacitors. All electrolytic capacitors, including high voltage filters and low voltage, high capacity by-pass condensers are checked at their correct working voltage on an English reading meter scale.

ACCURACY—Unique system of calibration

THE MODEL 543 is one of those rare values in a completely self-contained multimeter. A single rotary switch provides automatic operation of the four basic functions, OHMS, AC VOLTS, DC MILLIAMPERES,



SUPREME MODEL
543
MULTIMETER

DC VOLTS at 1000 ohms per volt standard sensitivity. This handy little instrument uses a full size 3" meter and beautiful bakelite case measuring only 3" x 5 3/4" x 2".

This is truly a tester that will fit your pocket and your pocket-book.

THE MODEL 542 is a regular little pocket laboratory with five multimeter functions including: AC VOLTS, DECIBELS, DC VOLTS, DC MILLIAMPERES, and OHMS-MEGOHMS. The unit is complete in every respect requiring no external batteries for the ohms and megohms ranges. A full size 3" meter with a sensitivity of 5000 ohms per volt (200 microampere movement) indicates the readings for 24 carefully selected ranges. This is a value that is not being overlooked by those who desire an ultra portable instrument that possesses the accuracy and utility of the larger testers.



SUPREME MODEL
542
MULTIMETER

SUPREME

SUPREME INSTRUMENTS CORP.
GREENWOOD, MISSISSIPPI, U. S. A.

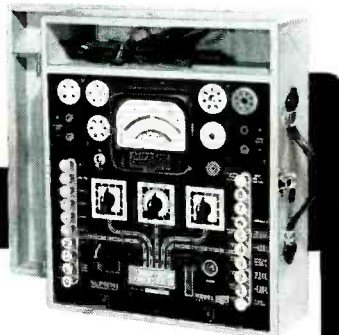

SUPREME MODEL 504-A

provides method whereby all AC and DC voltage ranges may be set in production to read exactly in accordance with laboratory standards. This means that the Model 504-A is well within the specified 2% and 3% tolerance. Therefore, after months and months of hard service you are still assured of an accurate DC and AC voltmeter.

OBSCOLESCENCE IS OUT!—In owning the Model 504-A, your worry about obsolescence is over. The Model 504-A is modern today and will be modern tomorrow. It provides filament voltages from .75 volts to full line voltage and it also has SUPREME'S PATENTED DOUBLE FLOATING FILAMENT RETURN SELECTOR SYSTEM which automatically re-connects every tube socket to the proper arrangement while the instrument is being set up from the roller tube chart. Tube base connections may change to any of the many hundreds of possible arrangements and the 504-A will take care of them—automatically. That's why the 504-A has only one socket for each type of tube.

EASY TO OWN—If you can afford a telephone or if you can afford cigarettes, you can afford the Model 504-A. For 18c per day you can own this complete laboratory, combining a 7-way tube tester, 31 range set tester, battery tester and condenser analyzer.

A parallel equalizer is shown at *C* in Fig. 4. This provides the same results as the series equalizer, but has the disadvantage that pickup response will vary somewhat with crystal temperature.

High-frequency response may be reduced by using a parallel condenser *C*, as shown at *D* in Fig. 4. The larger the capacity, the greater the attenuation of highs.

If sharp cutoff is desired, the series resistor *RI* may be added, as shown at *E* in Fig. 4. A larger value of *RI* will provide a greater attenuation of highs.

If bass response is too high, it may be reduced by the addition of the shunt resistor *RI*, as shown at *F* in Fig. 4. The lower the value of this resistor, the greater the attenuation of the bass frequencies.

If needle scratch is objectionable and no tone control is available in the amplifier, the simple tone control shown in Fig. 5 may be added to the pickup circuit. A variable control is desirable since it permits full response on records with quiet surfaces and a reduction in highs on records with worn or poor surfaces.

EQUALIZED CURVES

The characteristics of the Astatic Models FP-18 and FP-38 low-pressure crystal pickups are given in Fig. 6. Curves *B* show the increase in bass response that may be obtained by using a 2-meg volume control rather than one of 0.5 meg, as in curves *C*.

The effect of the addition of a series equalizer (*C-RI*) is clearly demonstrated in the curves *D* through *H*. It should be noted that the addition of the equalizer reduces the terminal voltage.

If a series equalizer is installed, it should be mounted as near to the grid of the input amplifier tube as possible. It should never be connected in at the pickup terminal unless the shielded lead from the pickup to the first amplifier tube has a length of only a few inches. Hum may be present if the pickup leads and the equalizer are not shielded.

THE CONSUMER

(From page 11)

ice station were gambling on a mild winter. Well, it was a poor gamble, for, in saving on possibly a quart of anti-freeze, they lost the family's business, which must have amounted to one hundred dollars a year at least.

FOOLING THE PUBLIC

Lesson No. 2 illustrates what we believe to be the acme of damnfoolishness. A radio engineer inquired of a friend why he was no longer using his midget

(Turn to page 28)

New!
GI-R70

Home Recording Sales for You

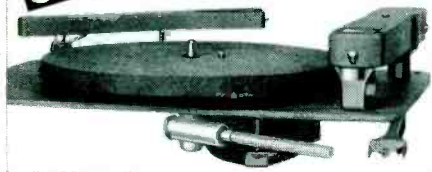

Special, sturdy motor; weighted turntable; concealed feed-screw mechanism; high impedance crystal pickup and separate, adjustable cutting head and arm. All mounted on attractive base plate, ready to install. Order one today for testing.

Low Cost — Easy to Install

● Open up new sales in average homes—in voice, music and drama schools—in business offices—with home recording simplified by the General Industries R70 unit. Easy to operate—customers are pleased. A volume seller.

Get our new free catalog and price list.

The GENERAL INDUSTRIES CO.

Dept. 17 Elyria, Ohio

Order Your Cutting and Play-back Needles from Our Affiliate.

General Phonograph Mfg. Co., Inc., Putnam, Conn.

NOTICE

INDEPENDENT SERVICEMEN

The Future Looks Very Bright

Many thousands of part-time and transient radio servicemen no longer compete with you. They have gone back to their regular jobs or are in the Defense Service. The untenable business conditions these part-timers were largely responsible for are fast disappearing.

RADIO MOVING DAY . . . March 29, 1941, when over 10 million push-button receivers will require resetting, is fast approaching. Here is one of the greatest opportunities you've ever had. Take advantage of it fully. Your customers, the broadcast stations in your territory and you will benefit. RSD shows you how to go about it. Read every issue of RSD for timely, exclusive technical data and for proven sales ideas that will surely help you make more money during the years to come.

Subscribe to RSD today—it is the *Technical Monthly With The Largest Circulation Amongst Leading Radio Service-Dealers, Soundmen and Parts Jobbers*. RSD publishes more important technical data than any other publication catering to radio servicers.

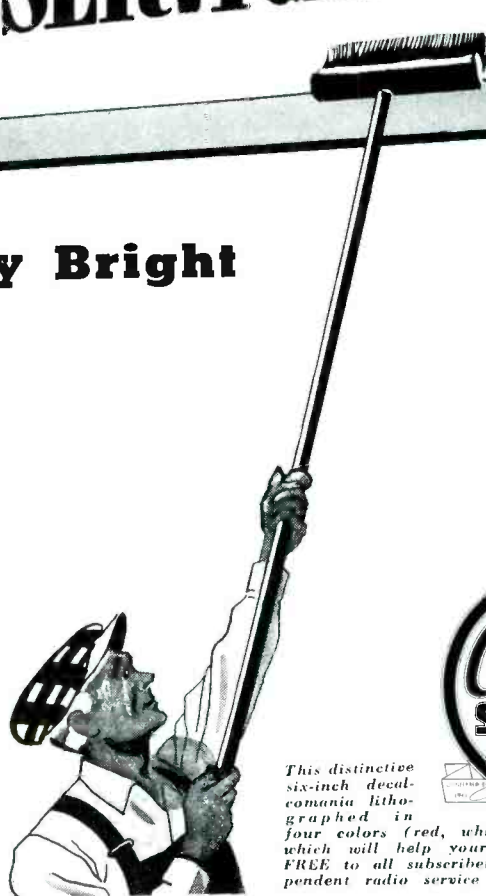

This distinctive six-inch decal-comania lithographed in four colors (red, white, blue and gold) which will help your business, available FREE to all subscribers classified as independent radio service dealers on request.

TEAR OUT AND MAIL TODAY

RADIO SERVICE-DEALER
 11 West 42nd Street, New York City, N. Y.

Sirs: Here is my check (or money order) for \$ Enter my subscription order to RSD for the next issues. (12 issues cost \$2.—24 issues cost \$3.) Canadian and Foreign subscriptions are \$3 annually. The information given below is accurate. If my subscription is rejected I expect an immediate refund in full.

Name (print carefully)

ADDRESS FIRM NAME Est. 19

CITY STATE YOUR POSITION

Please check whether firm is

<input type="checkbox"/> An independent servicing organization	<input type="checkbox"/> TUBES	<input type="checkbox"/> We own the following instruments:
<input type="checkbox"/> An independent service-dealer (engaged primarily in service work)	<input type="checkbox"/> PARTS	<input type="checkbox"/> V-T Voltmeter
<input type="checkbox"/> A service-dealer (does servicing, but is primarily interested in retailing)	<input type="checkbox"/> RECEIVERS	<input type="checkbox"/> Tube Checker
<input type="checkbox"/> Selling, renting or servicing Sound Equipment	<input type="checkbox"/> BATTERIES, etc.	<input type="checkbox"/> Analyzer
<input type="checkbox"/> Jobber	<input type="checkbox"/> SOUND EQUIP.	<input type="checkbox"/> Oscillator
<input type="checkbox"/> Manufacturer	<input type="checkbox"/> ELEC. APPL'LS.	<input type="checkbox"/> Signal Generator
<input type="checkbox"/> Any other classification (State it)		<input type="checkbox"/> Volt-Ohm Meter
		<input type="checkbox"/> Others
		<input type="checkbox"/> MANUALS

I belong to a serviceman's organization Yes No

(From page 26)

receiver. The friend said that it had gone dead and he had taken the tubes down to so-and-so, the radio serviceman, who had tested the tubes and found them all shot. The friend didn't feel that he wanted to invest in a complete new set of tubes at that time.

The engineer knew that it was unusual for the heaters of all tubes in an ac-dc set to go simultaneously, and offered to look them over. He found one tube burnt out. It was replaced and the set was okay.

There are two possibilities here:

Either the serviceman in question hoped to capitalize on the ignorance of a potential customer, or he was careless in testing the tubes and actually thought they were shot. Though he would be morally wrong only in the first instance, he is open to condemnation in either instance.

The fact that he sold no tubes at all to this man is a minor point. The unfortunate, though understandable, part of it is that both the radio engineer and his friend gave it the worst possible interpretation and have since gone out of their way to condemn the serviceman to other people. They were and are in no

frame of mind to give him the benefit of the doubt, yet it must be admitted that the serviceman might have a reasonable explanation. As it is, the harm he has done to his own trade through irresponsibility or carelessness, is incalculable.

SELF-PROTECTION

Lesson No. 3 is a problem in forewarning. A man's auto-radio went on the blink while he was on the road. He stopped at the first radio service station he saw, where they told him that two of the tubes were shot. These were replaced and the man went on his way. The set went dead again before he reached New York.

When he hit town, he went to an "authorized" service station where they handled his particular make of receiver exclusively. They informed him that the burnt out tubes had been replaced at the other service station by "second-handers" rather than new tubes. The man naturally hit the ceiling.

We haven't the foggiest idea as to who may have pulled a fast one in this case, and it would probably take the Supreme Court to decide. Anyhow, as a lesson, we are not interested in attempting to establish guilt, but to point out that the first service station in question should have insured itself against any such accusation—true or false—by testing both the old tubes and the new ones with the customer looking on. Assuming that the accusation was false—if the customer had seen for himself that the old tubes tested bad, and a new pair taken from the shelf tested good, he would have been in a position to form his own opinion. As matters stand, he may have become sold on a gang of high-binders who took advantage of a situation that could not be readily checked on.

In the article, "The Case of the Midget," which appeared in our January issue, it was pointed out that the serviceman should advise a customer that, in the event of a shorted first-section filter condenser, the rectifier tube will have been damaged. It would be poor policy to replace the condenser, say nothing about the damage done to the rectifier tube due to excessive current drain, and let time finish the tube. The customer doesn't know that one component can affect another, and if you keep him in the dark, you're going to be blamed for subsequent failures. If you have doubts about components that do not require immediate replacement, at least advise the customer that the components are more than likely on their last legs.

Do whatever you can to fully protect your own position, even if it costs you a bit extra to do so. It's better than losing customers right and left.



When Two Directions Are Better Than One USE UTAH BI-DIRECTIONAL SPEAKERS

The back wave, as well as the front, is utilized to deliver voice reproduction perfectly in the Utah Bi-Directional Speaker. Embodying the latest speaker design and construction features, it is especially suited for factory call and paging systems where high noise level is a factor.

The Bi-Directional Speaker cone resonance and response are matched to that of the attractive non-metallic case. An absence of excess low frequency response prevents distortion of voice. In addition to dustproofing the speaker, the case is treated to assure maximum freedom from dust and metallic particles.

Terminals of the Utah Bi-Directional Speaker are brought out through the case. It is not necessary to open it when installing. Choice of line transformers is included, tapped at 500 to 4750 ohms, marked clearly for hook-up. This permits the use of from 1 to 20 speakers on a 250 or 500 ohm line. Sturdy swivel base makes installation easy and enables speaker to be turned in any direction after mounting.

UTAH WALL REPRODUCER



This Utah speaker is identical in construction to the Bi-Directional; however, the response has been extended to reproduce music as well as voice. The case is of molded non-metallic material. The finish will blend with any decorative scheme. This unit is extensively used as an extra speaker for coin-operated phonographs — and as an additional speaker in homes, recreation rooms etc.

Write for complete information about these and other speakers in the complete Utah line. There is no obligation. Utah Radio Products Company, 836 Orleans Street, Chicago, Illinois. Canadian Office: 560 King Street West, Toronto. In Argentine, Ucoa Radio Products Co., SRL Buenos Aires. Cable Address: Utaradio, Chicago.



SERVICEMAN'S DIARY

(From page 19)

the car window, smiling to herself.

"Oh, that won't be necessary," I told her. "I know you're in a hurry and I can drop you off on the way. I'll make out all right anyhow."

But she insisted on coming along, even after I told her it had nothing to do with hitch-hiking and was simply a matter of fixing a defective police car receiver. I went on to tell her how much trouble we had been having with these old sets. She seemed interested in the communication system and asked that I show her the transmitter at the Station House. I told her I couldn't promise, as the Chief didn't like to have visitors brought in to the broadcasting office. But I promised to see what I could do.

We pulled up in front of the Police Station and both of us hopped out. I suggested that she wait until I went in and spoke to the Chief. But she insisted on coming in with me. At the Chief's office I stopped her.

"Now, listen," I said. "You'll have to wait here a moment until I speak to the Chief and see if it's all right for you to come in."

"Now, listen," she mimicked. "You just let me do the talking." And she barged right in to the Chief's office, with me tagging after her and, believe me, plenty disturbed.

I was kicking myself for having bothered with her, when she said, "Father, don't you think you ought to get some new radios for the police cars? The radio went bad in one this morning while this young man was giving me a lift. Now, if he had been a kidnapper—though perish the thought—you wouldn't have been able to broadcast a warning to Mac that someone in a truck was making off with me. And you wouldn't want to lose your only daughter, would you?"

And was that that? It was. The girl had turned the trick. For I know now he's going to see that the Village Board gets through an appropriation for those new sets.

But maybe I'll kidnap that only daughter anyhow. At least, I'll try . . . if she doesn't mind.

SALES HINTS

(From page 14)

sole set and a small record player for the children's room. Clever? We think so.

We know of another case where a service-dealer learned that a certain customer of his was a building contractor. During a servicing job on the con-

tractor's auto-radio, the service-dealer innocently asked if he had put inter-comm systems in any of the houses and buildings his company constructed, and how did they work out. The contractor was not acquainted with any systems other than the one the telephone companies will put in, and naturally asked questions. The service-dealer explained their simplicity and convenience and ended up with an order to install a complete system in the contractor's office as a "test case."

Since then, the contractor has put inter-comm equipment in some of the structures on which his company has worked, and though the service-dealer

did not get all of the business, he has been given some of the installation work and all of the servicing, when and if. And the contractor's recommendations have brought in business from other firms and individuals.

HEADWORK AND FOOTWORK

There is practically no limit to sales potentialities if you take advantage of opportunities. The instances cited above are true and demonstrate the point. It all boils down to a combination of headwork and footwork. One alone will not get you very far, but together they spell success.

To Simplify Resistor Replacements . . .

*Only \$6.00 list for two each of these 5 universal sizes.

Use Adjustable 10-Watt resistors for the Hard-to-Stock Sizes!



CLIMATE-PROOFED

IRC Power Wire Wound Resistors are made in a complete range from 5 to 200 watts—all standard types having the famous IRC "Climate-Proofed" Cement Coating to guard against the most common cause of power resistor failure.

Sure you try to stock frequently used resistor values in half, one and two watt sizes, but it's difficult to have them all on hand at all times, and it's tough to hold up a job while you wait for the one you need.

Stock a couple each of the IRC type ABA adjustable ten watt resistors, 500 - 1000 - 2500 - 5000 - 10,000 ohms,* each of them adjustable by moving the slider for any resistance value up to the maximum.

These five units will handle any wattage requirements up to 10 watts and any resistance value from 50 ohms to 10,000 ohms. Use the low range units for high wattage-low resistance requirements because in all cases the wattage rating is based upon the full length of the resistor.

IRC Type ABA 10-watt Adjustable Resistors are made in all popular ranges from one ohm to ten thousand ohms and list at 60c each.



POWER WIRE WOUND

RESISTORS

INTERNATIONAL RESISTANCE CO., 401 N. Broad St., Philadelphia, Pa.

NEW COMBINATION TESTER

TRIPLETT
MODEL 1183

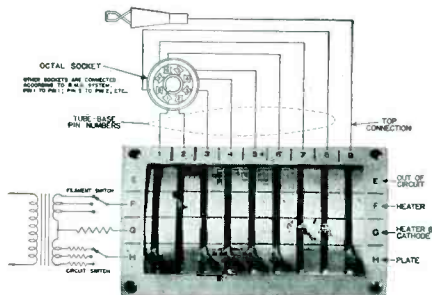
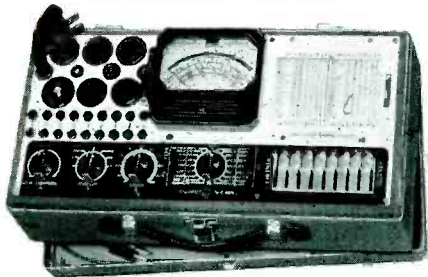

Combining simplicity of operation with absolute flexibility, Triplet's new lever switching permits individual control for each tube element — yet test procedure is simple and quick. The switch setting shown above will permit tests of 45 commonly used different type tubes without change of position of the levers. Many tubes require only two lever switch settings—more than half, only three settings. Model 1183 is truly a Non-Obsolescent Tube Tester, combined with a Volt-Ohm-Milliammeter and Free Point Tester... three fundamental testers that you can use for many years. Volt-Ohm-Milliammeter Ranges: 0-10-50-250-500-1000 AC and DC Volts; DC at 10,000 Ohms per Volt; AC at 2000 Ohms per volt. DC Milliampers 0-1-10-50-250; Resistance 0-500 Low Ohms; 0-15,000 Ohms; 0-1.5 and 0-15 Megohms. Complete Free Point Tester with sockets for all tubes, including new Midgets. Tube Tester has new lever type switch. Speedex Roll Chart, removable from panel as separate unit. Dealer Net Price \$49.84.

Wide Range

SIGNAL GENERATOR

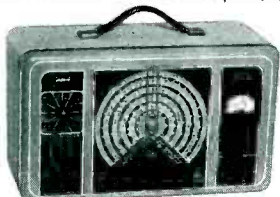

TRIPLETT
Model 1632

DEALER NET PRICE \$79.84

Model 1632—Continuous coverage . . . 100 Kc to 120 Mc. All frequencies fundamentals . . . Metered Output to multiplier and attenuator . . . Heterodyne Detector incorporated . . . Output Available at End of Coaxial Cable . . . Provision for External Modulation . . . Voltage Regulator Tube . . . Low Resistance Copper Shielding . . . Positive Vernier Dial Tuning Control . . . Accuracy and Stability beyond anything before demanded in the test field . . . Dealer Net Price \$79.84

Write for Catalog—Section 472 Harmon Avenue

THE TRIPLETT ELECTRICAL INSTRUMENT CO.
Bluffton, Ohio

RECONDITIONING

(From page 18)

evenings, were initiated with a door prize card planned on a ballot layout in step with the spirit of the then-approaching national election.

Mr. Coon's thoroughness in covering his subjects and the high interest developed in presenting them brought all meetings to a close with high enthusiasm. The volume of questions asked and thoroughly answered, warrants the opinion that Mr. Coon may well be a candidate for the year's most popular "quiz" program.

Now that sufficient time has passed since the institution of this ambitious program by a distributor to gauge the results, it may be put on record that the plan was an overwhelming success. Spokane reports that a daily volume of mail and long-distance phone calls breaking all past records confirms their estimate that the project will turn out to be the most beneficial ever attempted by them. It is the first time anything of its kind has been attempted in the northwest radio circles, and it bids fair to become a fixed practice in the operations of Spokane Radio.

That a similar project, instituted in other sparsely-settled sections of the country, would prove successful goes without saying.

MOTOROLA 35-F

(From page 12)

remove the broken pieces and turn gang condenser to fully meshed position. Cut a length of 18 lb. silk fish cord 27 inches long. Thread one end through hole C (Fig. 2) in condenser pulley and with an ordinary paper clip fasten it to the tuner bracket to hold in place. Run cord in a clockwise direction to idler pulley 1. Then route cord around idler pulley 1 and across chassis to idler pulley 2. Continue around pulley 2 and back across chassis to idler pulley 3. Route cord around pulley 3 and, in a clockwise direction, around condenser pulley to hole C, as shown in Fig. 2.

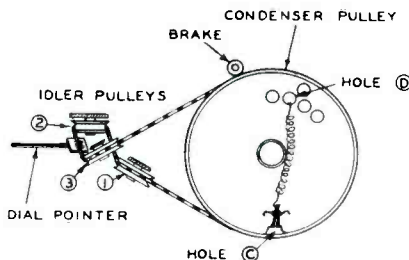

Fig. 2. Showing method of replacing broken pointer cord.



and it isn't
BALONEY!

SERVICEMEN and DEALERS everywhere will be called upon immediately to supply a large demand for F-M conversion units! Commercial F-M is now a reality and public attention is being attracted to this new system of true high-fidelity, noiseless reception. YOUR sales AND profits are due for a tremendous boost IF you take immediate advantage of the present opportunity to cash in on early demands for high quality, inexpensive adapters for present radio receivers, such as

the New Meissner



F-M RECEPTOR

This unit is a complete, self-powered, 8-tube converter, designed to add F-M reception to any regular receiver—feeds directly into the input of the audio system. Power output and tone quality are limited only by the capabilities of the audio equipment in the regular receiver! RF stage provides maximum reception range and noise rejection. In attractive walnut cabinet, the Receptor is only 13" wide, 7" high and 6 3/4" deep! Available without cabinet, if desired. Write for details and prices at once!

Write Today for Free General Catalog

Address Dept. D-7



Then remove paper clip and knot the two cord ends together inside of condenser pulley. Fasten one end of tension spring to cord and other end to hole D in the condenser pulley. Place a drop of shellac on cord knot. Cut off surplus cord and replace pointer.

To set pointer to correct frequency, tune in a station of known frequency and adjust pointer on cord. Fasten pointer to cord with a drop of shellac.

PORTFOLIO

(From page 17)

15,000 cycles. In fact, it would have shown only a slight increase in output at 35,000 cycles if it had been so tested with a sine wave audio signal. But the abrupt change which occurs in square waves from the positive peak to the negative peak creates the transient by an effect akin to shock excitation.

The overall frequency response of audio amplifiers can be determined at a glance by an examination of its response to a square wave input. The effect of high-frequency attenuation is shown in Fig. 4-C. Note the curvature of the square wave which, as injected, resembles that shown in Fig. 4-A. And, in Fig. 4-D, poor low-frequency response is indicated by such a trace when the input signal is similar to that shown in Fig. 4-A.

OTHER TESTS

Another new application of square waves is in the rapid alignment of wide-band amplifiers, such as are employed in f-m receivers. The type of modulated wave used for such purposes is shown in Fig. 5-A, which represents a carrier 100-percent modulated with a square wave of the type shown in Fig. 4-A. When the

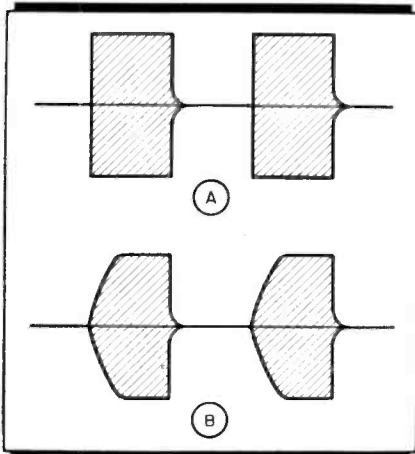

Fig. 5. A—Square wave 100-percent modulated. B—High-frequency attenuation due to too narrow a band.

AS CHIEF CONDENSER BLOWER OUTER OTTO OOMPH WAS A FLOPPEROO

Ever since Otto Oomph was a boy, he suffered from a strange disease. Smashophobia, the doctor called it—the horror of breaking things—but there was nothing to be done about it. When he broke a Christmas tree ornament one year, poor Otto cried for two days. When he grew up, he wouldn't shoot as much as a clay pigeon and even the thought of denting the fender of his car would make him sick.



Eventually, however, Otto became an electrical expert. That got him a job in the Sprague laboratories and Otto was really happy for the first time—that is, until someone made him Chief Condenser Blower Outer in the Test Division.

Now, voltage in the electric chair at Sing Sing is 1,200 volts. In contrast, controllable AC voltages in the Sprague lab run as high as 7,200 (and much higher in the special high voltage lab) for here is where Sprague condensers really get "the works." They are torn apart, blown apart, tortured and blasted, not only to see how good they are, but how to make 'em even better.

WHAM! Poor Otto jumped six feet when a can condenser, deliberately loaded with supercharge to determine its break-down point, exploded in a cage.

BAM! SNAPPETY-CRACK. Otto shivered as another condenser gave its life under 4,000 volts of DC.

CLICKETY-CLICK in monotonous regularity as AC refrigerator motor starting condensers were switched tortuously on and off 150 times an hour.

SIZZ-SIZZLE and SISS as vapor streams played on condensers to prove their moisture-proof ability.

In a massive oven, dozens of units were undergoing life tests at 200° F. Elsewhere, Television condensers were telling their story under 3,000 to 10,000 volts of DC; tiny electric razor condensers were getting the equivalent of 14 years of the hardest kind of use; and, almost every minute some condenser gave up the ghost and another fact was added to the science of constructing condensers that excel in the rough and tumble usage of the field.

"I can't stand it—I can't stand it," wailed Otto at last, weeping over the remains of an 8 mfd. 450 V. Atom midget dry.

"Gosh, Otto," consoled an engineer. "What you worrying about? That condenser is only rated at 450 V. We had to smack it with a surge of almost 700 V. before it went."

"Sure," sobbed Otto. "But I can't stand this business of busting things. It ain't fair to treat such swell condensers so downright mean. It makes me sick. I—I wanna quit."

And quit Otto did. 'Twas a year before we heard from him again and then he wrote:

"Dear Boss: Maybe you think I was silly to quit my job, but it just isn't my nature to bust things up. I'd go home nights and dream about condensers on those torture racks—the finest condensers in the world just waiting to be blown up even if it took all the power in Massachusetts to do it.

"But all's well that ends well. I'm in the radio service business and doing fine. I use Sprague Condensers—and boy, are they real! Not a blow-out in a carload. No failures from moisture—or anything else in fact. I realize it's largely because of the work you guys are doing back there in the lab, but I still say blowing up condensers is a helluva job for a sensitive man like me. Love and Kisses. OTTO OOMPH"

SPRAGUE PRODUCTS COMPANY
North Adams, Mass.

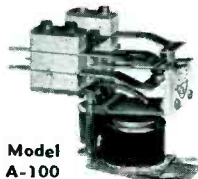

Model A-100

Antenna Change-over — Break In — Heavy Duty Keying in the primary with contacts in parallel — Grid Controlled Rectifier Keying—many other uses.

GUARDIAN ELECTRIC

1633 W. Walnut St.

Chicago, Ill.

Have You Moved?

Notify RSD's circulation department at 11 West 42nd Street, New York City of your new address 2 or 3 weeks before you move. The Post Office Department does not forward magazines sent to a wrong address unless you pay additional postage. We cannot duplicate copies mailed to your old address. Thank You!

YOU'RE THE DOCTOR

... and you can prove it!



HERE IS Hygrade Sylvania's latest sales-builder . . . a radio chassis chart that will discourage the most optimistic home tinkerer.

More clearly than any other promotion piece we've ever seen, "What Is Wrong With Your Radio?" convinces your customer that only an expert can make radio repairs . . . and YOU'RE THE EXPERT.

Write Hygrade Sylvania Corp., Dept. RSD-21, Emporium, Pa. for a free copy of this mailing piece . . . and for full information on the 25 other silent salesmen Hygrade Sylvania offers you either free, or at substantial savings.

Sylvania's Silent Salesmen

- | | |
|---|--|
| 1. Window Displays, dummy tube cartons, timely window streamers, etc. | 15. Service hints booklets |
| 2. Counter displays | 16. Technical manual |
| 3. Electric Clock signs | 17. Tube base charts |
| 4. Electric Window signs | 18. Price cards |
| 5. Outdoor metal signs | 19. Sylvania News |
| 6. Window cards | 20. Characteristics Sheets |
| 7. Personalized postal cards | 21. Interchangeable tube charts |
| 8. Imprinted match books | 22. Tube complement books |
| 9. Imprinted tube stickers | 23. Floor model cabinet |
| 10. Business cards | 24. Large and small service carrying kits |
| 11. Door knob hangers | 25. Customer card index files |
| 12. Newspaper mats | 26. Service Garments |
| 13. Store stationery | 27. 3-in-1 business forms |
| 14. Bill heads | 28. Job record cards (with customer receipt) |

SYLVANIA

SET-TESTED RADIO TUBES

Also makers of Hygrade Lamp Bulbs, Hygrade Fluorescent Lamps, and Miralume Fluorescent Light Fixtures.

band is too narrow, high-frequency attenuation results, just as in a-f circuits. This is shown in Fig. 5-B. Note the similarity between the wave shape of the audio envelope of this modulated wave and that of Fig. 4-C, which represents the results of an equivalent condition in an a-f amplifier.

It should be mentioned in passing that many other effects can be detected by means of these square waves. In audio output circuits, for instance, the transient peaks which result when an output transformer is improperly loaded, or when the voice coil of the speaker employed is not properly matched to the transformer, often will cause transients which resemble that of Fig. 4-B. The magnitude of the transient, which may be due to "hangover" causing a blurring of the speaker response, is usually greater with pentodes than with triodes. Properly used, however, inverse feedback has the tremendously valuable feature of reducing "hangover" to negligible proportions and thus makes for greater clarity of reproduction. It is often such obscure troubles, quickly noticed by a layman, which may be overlooked by the expert, because he bases his judgment on the fact that the amplifier passes conventional tests without showing trouble.

It should be understood that many of the square-wave tests shown here require special equipment which is not yet available to the serviceman; at least, not at a price within reason. It is likely, however, that simplified versions for receiver alignment, or square wave generators designed to be used with cathode ray 'scopes now owned by servicemen, will eventually appear on the market. They will not replace modern troubleshooting methods, but they may serve to simplify some of the more difficult alignment problems in receivers now appearing, or those which will eventually become available.

We hope that this data has provided a broader picture of the high-fidelity receiver problem. Insofar as the actual trouble-shooting, alignment and repair of such receivers is concerned, it is recommended that the procedure specified in the service notes covering the particular receiver under consideration be carefully followed. This is particularly the case with the alignment of the intermediates. If no 'scope is available follow the procedures suggested in signal-tracing manuals.

DISTINCTIVE CALLS FOR FM

To provide distinctive calls for frequency-modulation broadcast stations, the Federal Communications Commission has adopted a new system of call letters with interposed numbers for this now commercially recognized broadcast service.

Under international agreement, to which the United States is a party, the first letter (in some cases the first two letters) of a call signal indicates the nationality of a station. The United States is assigned the use of three letters—N, K, and W. Hence the present domestic assignment of combinations beginning with these letters. Call letters beginning with N are reserved for the exclusive use of the Navy and Coast Guard. Call letters beginning with K are assigned to broadcast stations located west of the Mississippi River and in the territories. Call letters beginning with W are assigned to stations east of the

HERE'S THE INSTRUMENT YOU'VE WANTED . . . AT A PRICE THAT REPRESENTS REAL VALUE!

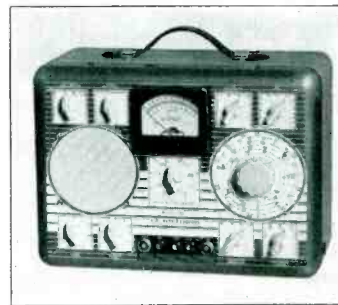

WEBBER "230" SIGNAL TRACER

Increase your profits by speeding up your service work with the Model 230. With this instrument you can perform any service job better and faster by actually tracing the signal from the aerial to the speaker.

FREE! Webber engineers have compiled a complete Manual of Operation for Signal Tracers . . . not a catalog but a text book explaining tests and how to make and interpret them. Write for your free copy before the supply is exhausted.

... AND HERE'S A BRAND NEW SOURCE OF EXTRA PROFIT!



WESTMINSTER Electric Door CHIMES

Westminster Chimes are growing in popularity by leaps and bounds—replacing old-fashioned door bells and buzzers almost everywhere they're shown. And a big share of this profitable business can be yours . . . by simply showing a Westminster Chime at the conclusion of each service call you make. You'll find that its beauty of tone and appearance coupled with low list prices makes almost every call a sale. Installation charge is added profit.

Write for catalog, prices and free "self-demonstrating" Counter Display. You'll find that each installation will "sell the neighbors" as well. (Westminster Chimes are manufactured and sold by the Westminster Guild Division of the Earl Webber Co.)

EARL WEBBER COMPANY

4352 W. Roosevelt Rd.

Chicago, Ill.

Mississippi River. Any existing call letters not in accordance with this procedure is due to the fact that the station was licensed before the allocation plan was adopted.

Consequently, the first call letter of an f-m station must be K or W, depending on its geographical location.

A second letter for an f-m station will be assigned in alphabetical order (with exception of E, which will be reserved for non-commercial educational stations using frequency modulation) to each station on a given frequency as licensed,

thus providing 25 stations in each area for a given frequency. If more than 25 stations are assigned on a given frequency, an additional letter will be necessary.

However, between the initial letter and supplemental letter (or letters) two numbers will be utilized. These numbers will indicate the frequency assignment. This is possible because all f-m stations are in the 42,000-50,000 kilocycle band, and because all f-m frequencies are assigned on the odd hundreds in kilocycles. Thus, the first figure and the last two figures of the frequency assignment can be dropped.

In addition, and where possible, the city or area will be indicated by the second letter or a combination of second and third letters. Letter combinations of this mnemonic character have been assigned to each of the metropolitan trading centers. Thus, stations in Boston will terminate with the letter B, while stations in New York City will terminate with NY. Similarly, stations in the District of Columbia will be identified with the suffix DC.

In brief, here is how the system works: W41B would indicate an f-m station in the eastern section of the country (Boston) operating on the frequency of 44,100 kilocycles. By the same token, K43SF would apply to an f-m station in the western part of the United States (San Francisco) on the 44,300 kilocycle frequency.

The letter E in the alphabetical arrangement will identify non-commercial educational broadcast stations employing f-m on the new high-frequency broadcast band. Five channels (42,000 to 43,000 kilocycles) are available to these educational stations.

There is no international regulation to bar the use of this f-m identifying system. In fact, a like principle is followed by Chile in assigning calls to standard broadcast stations in that country. The arrangement provides ample source of calls for future f-m stations. It is about the only source of new call combinations which can be adapted, inasmuch as other types of calls are assigned by treaty to stations and services other than broadcast. It has the additional advantage of permitting identification of the frequency actually used, and for that reason should be popular with listeners as well as broadcasters.

Further, it will not disturb the approximately 15,000 remaining four-letter call combinations which are being assigned to the older services at the rate of between 40 and 50 a week. Even if this average does not increase, such a reservoir will not last more than six years. It should also be noted that under international treaty, ship stations have priority in the assignments of radio call letters from the four-letter group.

L-C CHECKER



Introduced originally for quicker and more profitable radio diagnosis, the L-C Checker—"The Miracle Instrument"—has steadily grown in popularity. Now used by lab workers, production staffs, maintenance departments and others in addition to leading servicemen. The handiest and most versatile means for checking condensers, inductances, circuits, antenna systems, oscillators, etc. Note these typical uses . . .

- ✓ Checks effective capacity at r.f. of condensers actually left in circuit. No disconnecting; no unsoldering; no loss of time.
- ✓ Aids in aligning r.f. and i.f. circuits, tracking super-het oscillators, etc.
- ✓ Used in aligning broad and narrow u.h.f. amplifiers. Aids tuning of wave traps and image-rejection circuits.
- ✓ Identifies harmonics of frequency standard in precision frequency calibration of radio equipment.
- ✓ Checks resonant points of chokes, shorted windings (unused coils) etc.
- ✓ Checks natural period of antenna and r.f. transmission lines, etc.
- ✓ Performs countless other functions, yet costs but \$29.50 (Your Net Cost) complete with tubes and instruction manual.

Ask to See It . . .

- Ask your local Aerovox jobber to show you the L-C Checker. Note its simple operation. Ask for latest literature—or write us direct.

AEROVOX
CORPORATION
NEW BEDFORD, MASS.
IN CANADA: AEROVOX CANADA, Limited Hamilton, Ont.

For the Best of Service OHMITE RESISTANCE UNITS



Servicemen and Engineers everywhere have standardized on Ohmite Resistance Units for dependable, trouble-free performance. See Your Jobber for:

Cordohms—replace internal voltage dropping resistor in AC-DC radio sets. Also Tapped Cords for pilot lights.

Dividohm Resistors—Easily adjusted to resistance you want.

Brown Devils—10 and 20 watt resistors for voltage dropping, bias units, bleeders, etc.

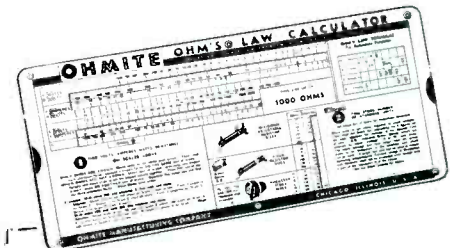

New OHMITE Ohm's Law Calculator

Solves any Ohm's Law problem with one setting of the slide! No slide rule knowledge required. All direct readings. Only 10c to cover handling cost. At your jobber or send coupon.

Ohmite Manufacturing Company
4846 Flournoy Street, Chicago, U.S.A.

10c in coin enclosed. Send Ohm's Law Calculator.

Name

Address

City State

Occupation

Radio Service Dealer—Feb.

OHMITE
RHEOSTATS RESISTORS TAP SWITCHES

SELL SUNCO MUSICAL TOWERS CARILLONS



A SUBSTANTIAL CONNECTION!

We can offer a substantial connection to established, rated sound men. Our line is Chime Carillons, Automatic Reproducers, and Musical Tower Recordings. We advertise in a lengthy list of the leading church papers, and also conduct direct mail campaigns. We receive inquiries from substantial individuals of means and active organizations, interested in using our products for memorial, institutional and other purposes. These inquiries we turn over to our nearest representative. The representative earns a substantial profit.

SELLING SUNCO PRODUCTS

We not only provide real leads as received, and help follow-up, but supply equipment superlative in quality and workmanship, and capable of performance equating that of carillons costing ten times more.

EXCLUSIVE RECORDINGS

The Sunco Chime Carillon has exclusive patented features; for instance, micro-tuning to 1/5000 of 1%! Played from electric keyboard, by hand, or record—automatically and time-controlled, if desired. For recorded programs, we have an extensive repertoire of sacred and semi-sacred music for musical tower—unexcelled by anything of the kind. We have a really substantial connection to offer, and if you are definitely interested and preferably rated in Dun & Bradstreet, write us. Also ask for our list of recordings.

SUNDT ENGINEERING COMPANY

4789 Ravenswood Avenue Chicago, Illinois

RADIO IN NATIONAL DEFENSE

The application of power and special purpose radio tubes and radio test equipment to industry's speed-up program for national defense, is the heart of a pioneering plan developed by the Tube and Equipment Division of the RCA Manufacturing Company.

Applications of new electronic measuring devices to industry, and new methods of testing in the research laboratory and on the production line, are but two of the many jobs radio equipment is prepared to do for industry. Modern electronic equipment stands ready to assist in keeping industrial operations going at full speed, and in developing new methods of doing things better and faster.

The first of a series of educational meetings under the sponsorship of the RCA Tube and Equipment Division for its distributors to further the development of the plan has been held already in Pittsburgh. More than 100 research, industrial and design engineers were in attendance from steel mills, railroads, power companies, and a wide variety of manufacturing organizations. The meeting, conducted by engineering experts from RCA's headquarters, was held under the auspices of the Cameradio Company, RCA tube and equipment distributor in Pittsburgh.

J. A. Fried, sales engineer of the RCA Engineering Products Division, participated with a discussion of the applications of electronic measuring equipment such as the RCA ultra-sensitive d-c meter and other instruments. Mr. Fried pointed out that the meter, while practically indestructible, may be used where a sensitive and delicate galvanometer-type instrument would be used for such micro-ampere measurements as determining the output of photo-electric cells, or measuring galvanic currents.

Among other units recently developed by the RCA Engineering Products Division for wide industrial applications are an electronic switch which permits placing two tracings on a cathode-ray oscillograph at the same time for comparative readings; a noise meter which, among other applications, may be used to measure radio interference generated in electrical apparatus; industrial measuring equipment for studying dynamic pressure wave forms; and equipment for studying vibrations, with suitable conversion units for converting the vibrations into an electrical a-c voltage of similar wave form, magnitude and frequency so that they can be illustrated upon the screen of a cathode-ray oscillograph.

W. H. Bohlke, Director of Test Equipment Merchandising, revealed many new methods of laboratory and production testing with modern test equipment.

CINAUDAGRAPH SPEAKERS



"of course, if you want the best . . ."

On those occasions when "something just as good" won't do you can save the day with CINAUDAGRAPH.

Whether in a fine radio or 'way up on a pole . . . a CINAUDAGRAPH SPEAKER does what is expected of it in a manner that causes you to throw out your chest with pardonable pride and satisfaction.

Send for new catalog

STAMFORD CONN.

Now! WATCH YOUR WALCO NEEDLE PROFITS SOAR

WALCO GENUINE SAPPHIRE NEEDLES ARE NOW STANDARD EQUIPMENT IN THE NEWEST MODEL PHONOGRAPHS. ADOPTION BY NATIONAL MANUFACTURERS CREATES A VAST NEW REPLACEMENT MARKET FOR YOU.

New Low Price
former list price ~~\$1.50~~ Now \$1.00

Since becoming an integral part of the new, "big name" phonographs, WALCO SAPPHIRES are now produced in such tremendous volume that this new low price is possible. NOW, the leader of long-playing needles COSTS NO MORE!



Brand new "dressed-up" WALCO package—mounted 12 to a self-selling counter dispenser card—designed to quadruple needle sales.

Be prepared for soaring demand created by the new, popular price, and the prestige of "big name" advertising. Get behind WALCO.

WRITE OR WIRE TODAY for new stock plus free consumer literature.

ELECTROVOX COMPANY
424 MADISON AVENUE, NEW YORK CITY

WALCO
Sapphire Needles

COMING!

1941 Radio Parts

NATIONAL TRADE SHOW

Stevens Hotel • Chicago

TUESDAY TO FRIDAY
JUNE 10 TO 13

JOBBER DAYS
TUESDAY, JUNE 10
TO THURSDAY, JUNE 12

OPEN HOUSE
THURS. EVE. FFIDAY
JUNE 12 JUNE 13

Radio Parts National Trade Show
Executive Office
53 West Jackson Boulevard • Chicago

JACKSON

**Dynamic
TUBE TESTERS**



Model
636
Only
\$29.95

The most accurate Tube Tester you can possibly buy! Jackson's patented Dynamic circuit makes a better test—frequently finding "poor" tubes which might pass for "good" in ordinary testers. And because the Jackson Dynamic circuit is less complicated, quality instruments cost less.

Dynamic ANALYZERS

Jackson's Dynamic signal testing is direct, positive. Measures the signal itself, tracing its path through the receiver to the exact point of the trouble.

OSCILLATORS

Write for
FREE Folder

Jackson Audio Oscillators operate on a new basic principle—audio frequency voltage is developed at its fundamental frequency. ASK YOUR JOBBER about JACKSON INSTRUMENTS. **THE JACKSON ELECTRICAL INSTRUMENT CO., Dayton, Ohio**



MUELLER CLIPS

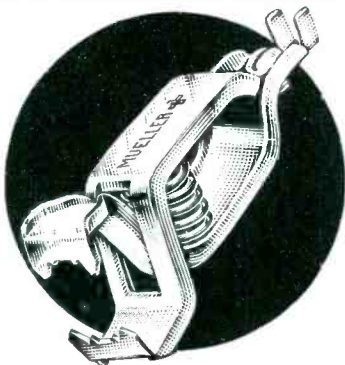

For 32 years Mueller Clips have been recognized as the best. **THE ORIGINAL AND ONLY COMPLETE LINE.**



Alligator Clip with Red & Black Insulated handles.



Crocodile Clip with Red & Black Rubber Insulators.



Pee-Wee Clip—also made in solid copper for R.F. Test Work.



MADE IN 10 SIZES, STEEL OR SOLID COPPER, INSULATED OR UNINSULATED.

The well known Clamp-Pipe Ground Clamp. 5 point contact. Will not lop over or spread apart.

CLAMPPIPE

Send for free samples and catalog 806

Mueller Electric Co.
1566 East 31st St. Cleveland, Ohio

D. Y. Smith, RCA Power Tube Sales Manager, told the engineers how special purpose radio tubes may be applied to such electronic devices as counting and sorting machines, switches, railroad signals, etc. W. E. Bahls, special tube engineer at RCA's Harrison, N. J., plant, revealed how radio tubes are designed with certain characteristics for special industrial applications.

L. W. Teegarden, Manager of the Tube & Equipment Division, explained that the purpose of the series of meetings being planned by the Tube and Equipment Division is to let industrial engineers know where they can find the radio experts in their locality who have highly specialized training for applying electronic devices to industrial uses, and where the instruments and equipment may be obtained.

SHOP NOTES

(From page 23)

RCA RP-145, RP-152 RECORD CHANGER

Centering Rotor

Should centering of the rotor be necessary, it may be accomplished quickly in the following steps:

Remove the two long machine screws, and lift off plastic end cover.

Loosen the two remaining screws sufficiently to permit adjustment of stator laminations.

Insert a .010-inch speaker shim between the rotor and each of the four stator field poles. Rotor should now be equidistant from each pole, and accurately centered.

Tighten screws and replace plastic cover.

RCA RP-153 RECORD CHANGER

Motor Data

Should it be necessary to rebuild or service any of these motors in the field by replacing end heads or using new rotors and shafts, it must be noted that the rebuilt motors should be operated continuously for at least 48 hours before installation. The use of bronze bearings, diamond-bored for accuracy, together with the burnished steel shaft at the rotor provides a very close fit. As a result, the motor must be run in approximately 48 hours, after which the oil has had a chance to fairly cover all contact surfaces of shaft and bearings, and a very smooth-operating long life bearing results.

RCA QB2

Reactivating Rectifier

The "A" supply in the CV-112 power unit (used in Model QB2) is supplied through a copper-oxide dry-disc rectifier. If the radio ceases to operate or drops off in performance, it may be due to a chemical change in this rectifier, which causes the "A" voltage to drop low enough to affect the performance of the receiver. The normal "A" voltage is 1.5 volts.

EXPOSED!



It seems that Homer G. Snoopshaw, B.R.S., (Battery Replacement Specialist), hasn't been strictly on the up-and-up in his capacity as Vice-President-In-Charge-of-Replacements. As we understand it, one of the helpers, jealous of Homer's rapid rise in the personnel of Bud's Radio Shop, did a little snooping on the snooper, and found that Homer had a copy of the Burgess Replacement Guide* up his sleeve. The candid camera shot shown above is evidence that Homer can't explain—and *is his boss burned up!* We suspect that Homer will soon be "at liberty" again.

Does anybody in the audience need a Replacement Adviser?*

***IT'S FREE**
See Your Burgess Distributor or write Burgess Battery Company, Freeport, Illinois

BURGESS
The Complete Replacement Line



BRACH Antennae

Automobile
Home — All types
F-M Systems
Television
Police • Marine
Multiple Systems
Complete Kits
Accessories

Made by World's Oldest and Largest
Manufacturers of Radio Aerial Systems

L. S. BRACH MFG. CORP.

55 DICKERSON STREET
NEWARK, N. J.



This condition is more likely to occur in the rectifier when the power unit has been out of service for a long time (four months or more).

To reactivate the rectifier it is only necessary to short the "A" plus and "A" minus terminals of the socket by connecting them together with a piece of wire for a period of *four minutes*. The high temperature developed in the rectifier during this period has the tendency to restore the discs to their normal rectifying ability.

(g) Use dry cloth to wipe decal and cabinet surface clean.

Replacement decals are listed in Service Notes, and may be obtained under the correct stock numbers.

STEWART-WARNER 5R CHASSIS

Increasing Sensitivity of 5R Chassis

In those locations where extreme sensitivity is necessary in a radio set, the 5R wood cabinet models (5R4, 5R5, 5R6 and 5R7) can be stepped up by the introduction of a slight amount of regeneration. This change can easily be made as follows:

Disconnect the .05 mfd condenser 23 from the suppressor grid terminal of the 12SK7 socket. In the underwriters approved sets (Model 03-5R, etc.) connect it instead to the B- terminal of the volume control. This is the terminal nearest the 12SQ7 socket, and is clearly indicated in the tube socket voltage layout of the service manual. In non-approved models (07-5R, etc.) connect condenser 23 to ground.

After the condenser change has been made, re-align the receiver. It is especially important to re-adjust trimmer 9, the broadcast oscillator padder, exactly as explained in the service manual. When aligning, keep the chassis away from the loop or oscillation may occur.

This change cannot be made on any of the plastic cabinet 5R sets (5R1 and 5R3). The plastic cabinet sets of this series will oscillate if they are stepped up beyond the present limit of sensitivity by this means.

RCA DECAL REPLACEMENT

Instructions for installation or replacement of decalcomania transfers on RCA Victor wood cabinets are as follows:

- (a) Remove old decal using benzine and a block of felt, rubbing in the direction of the wood grain. Clean surface thoroughly.
- (b) Apply thin coat of "Meyercord Cement" (clear varnish) on the back side of the decal. Let dry until it becomes tacky.
- (c) Apply decal to cabinet, rubbing gently over decal, making sure it is in complete contact with cabinet surface.
- (d) Remove top layer of paper, immediately after decal has stuck, by peeling off, after starting with finger nail.
- (e) Apply water to last "tissue" of decal with a sponge or rag, until the tissue can be rolled off.
- (f) Use a slight amount of benzine on a cloth to remove excess varnish film from the cabinet. *Do this gently!*

IF

You Are NOT a PAID Subscriber to

Radio
SERVICE DEALER

You May NOT Receive The Next Few Issues

You Can't Afford To Miss A Single Copy

SUBSCRIBE TODAY

We're Not Fooling, Mr. Serviceman!

**➔ NATIONAL DUES IN THE RSA ARE
➔ ACTUALLY ONLY \$1.00 A YEAR**



Yes—it seemed amazing . . . incredible . . . but Servicemen found it was true. Now hundreds of applications are pouring in from all parts of the country! Just think—a full year's membership in the National RSA for only \$1.00 (that's less than 2c a week).

You get the RSA Membership Certificate and the RSA House Organ. You have access to RSA Technical Helps Bureau, and you can participate in all the other functions and benefits RSA offers.

It's your big chance to join with thousands of your fellow Servicemen in this great national organization and have a voice in your own destiny. It's your big chance to help yourself get ahead in your industry.

Protected territories will be established as rapidly as local chapters are formed. Applicants in present chapter areas will be referred to the local chapter.

Fill out the coupon, attach a \$1.00 bill and mail it in today.

RADIO SERVICEMEN OF AMERICA, INC.

"Reliable Service Assured"

**JOE MARTY, JR., EXECUTIVE SECRETARY
304 S. DEARBORN ST., CHICAGO, ILL.**

**RADIO SERVICEMEN OF AMERICA, INC.
304 S. Dearborn Street
Chicago, Illinois**

\$1.00 enclosed for 1941 National Dues in RSA

Name
Address
City State

Radio Serv. Dealer—Feb.



Complete
NET
only
\$10⁵⁶



Always THE RIGHT
REPLACEMENT CONTROL
WITH THIS Centralab
PORTABLE

Adashaft Kit

You name the set and it's a hundred to one that you can do a replacement job right out of our PORTABLE Adashaft Kit . . . mighty good business sense . . . owning one of these kits . . . The strong steel case is 12" x 5" x 1 1/2" . . . you can even carry it in your coat pocket (note Old Man Centralab above) and you pay for the controls only . . . we give you the case "FREE".

Any shaft and control can be combined in a moment without special tools. Yet the RESULT is just as STRONG and RELIABLE as a ONE PIECE SHAFT.

Then replace the controls from your jobbers stock as they are used. Buy that ADASHAFT KIT today . . . you need it.

CENTRALAB Div. of Globe-Union Inc., Milwaukee
Cable Address — Centralab

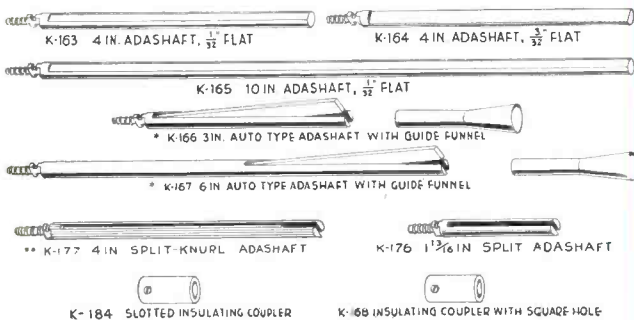
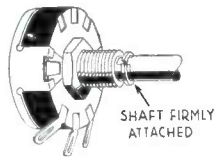
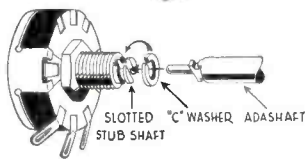

INCLUDED IN THIS ADASHAFT KIT
ARE THE FOLLOWING CONTROLS:

1 EACH OF

10,000	ohms
25,000	ohms
50,000	ohms
250,000	ohms
500,000	ohms
1 MEG	ohms
2 MEG	ohms
3 MEG	ohms
250,000	ohms
500,000	ohms
1 MEG	ohms
2 MEG	ohms

CURVE

3
3
6
6
6
6
6
6
6
tapped
tapped
tapped
tapped

SHAFTS

3	K163
2	K164
1	K165
1	K166
1	K167
1	K176
3	K177

COUPLERS

1	K184
1	K188

SWITCH COVERS

5	K155 SPST
1	K157 DPST

Centralab



Over 50,000 pieces of test equipment given away **FREE**

A CROSS SECTION OF NATIONAL UNION'S Honor Roll of Service Dealers

RALPH M. BOLICK, Bolick Bat. & Elec., Noosho, Mo.—Have had 20 equipment agreements during the past 7 years. I like to do business with N. U. for I find N. U. products and promotion helps outstandingly.

20 Contracts



41 Contracts

LOUIS E. CONNER, Radio Serv. Manager, Piper & Taft, Seattle, Wash.—After using thousands of N. U. tubes during the past seven years we find that we have had fewer replacements than of any other make. Most of our equipment has been secured the N. U. way.



15 Contracts



14 Contracts

J. G. COONEY, Conney Radio Co., St. Louis, Mo.—Thanks to N. U. Equipment Deals my shop is one of the most completely equipped testing laboratories in the city. I find N. U. products are the quality products in the industry and continually recommend them to other dealers.



CLARENCE E. ESTELL, The Fixit Shop, Lima, Ohio—N. U. equipment deals are the biggest contribution any manufacturer has ever offered to the radio service profession. In spite of cut-throat competition I sell at retail price because I can offer more for the money.

15 Contracts

E. A. MAGNOL, Boston, Mass.—In my opinion, and in the opinion of many other service engineers with whom I am associated, N. U. enjoys a prestige which needs no apology. Modern radio sets demand modern testing equipment. N. U. supplies it the easy way.

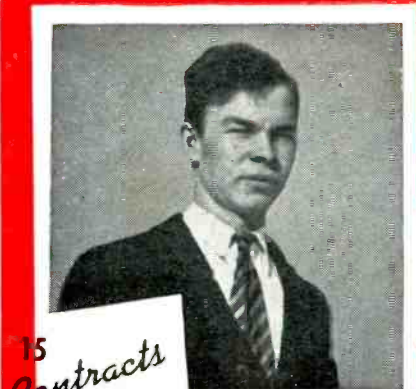
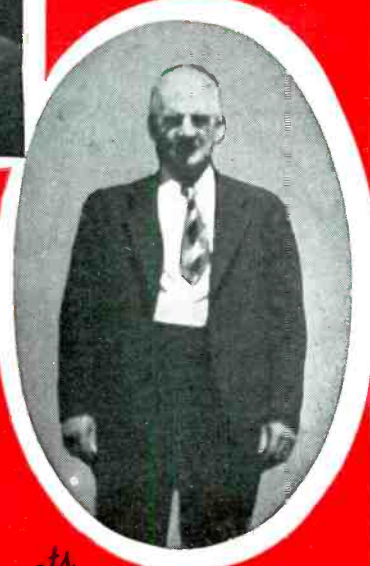

15 Contracts

VERNON M. HOOK, Bazre, Vermont—N. U. has something in Free Equipment Deals that no other manufacturer can offer—One of the largest items of expense to the dealer is up-to-date test equipment. What way could be easier than selling N. U. products?



29 Contracts

MATTHEW J. BERLOWITZ, Dunbar Radio Shop, Waukegan, Wis.—I have checked my records and I find that I have signed 29 contracts. There is no better way for a service man to profitably acquire good service equipment. In my 10 years of exclusive dealing with N. U. their product has always been satisfactory.

23 Contracts

F. E. STAGE, Longview Radio Sales & Service Co., Longview, Wash.—To me your Free Equipment Deal is great—Have signed 23 N. U. Equipment Deals—have been using N. U. product 9 years. N. U. tubes are the only ones rarely have to make replacements.

Copyright 1941 N. U. Radio Corp

You too can have the "Best Equipped Shop in Town"—See your N. U. Distributor or Write

NATIONAL UNION RADIO CORPORATION

57 STATE STREET, NEWARK, NEW JERSEY

Supreme in Quality